

CRYO-COOLING: why and how?

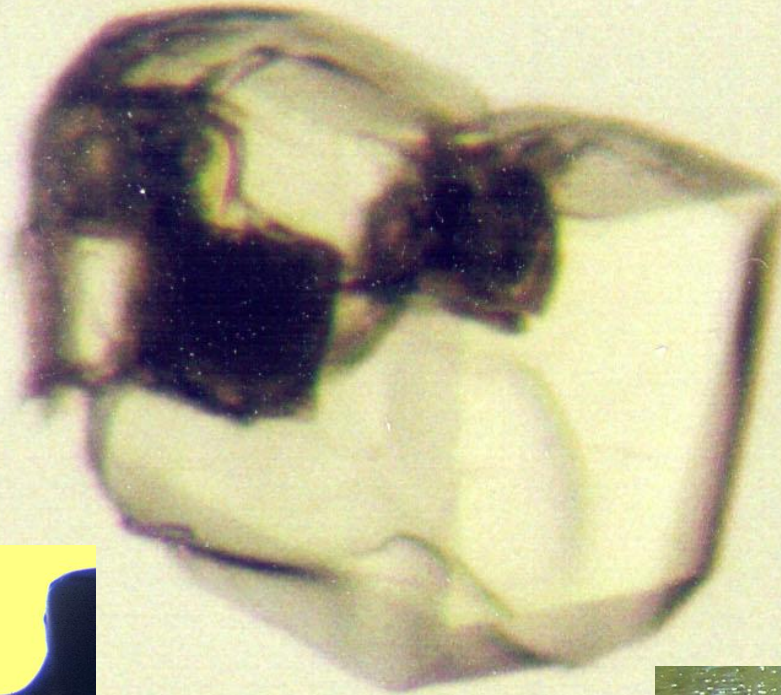

**CCP4/DLS
Workshop,
November 2017**

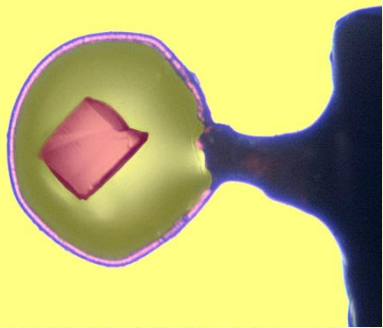

Elspeth Garman,
LMB, Oxford
Elspeth.garman@bioch.ox.ac.uk



Data quality pivotally affects the amount of biological information we obtain.

Copyrighted Farside cartoon of Dirk finding the structure of dirt.

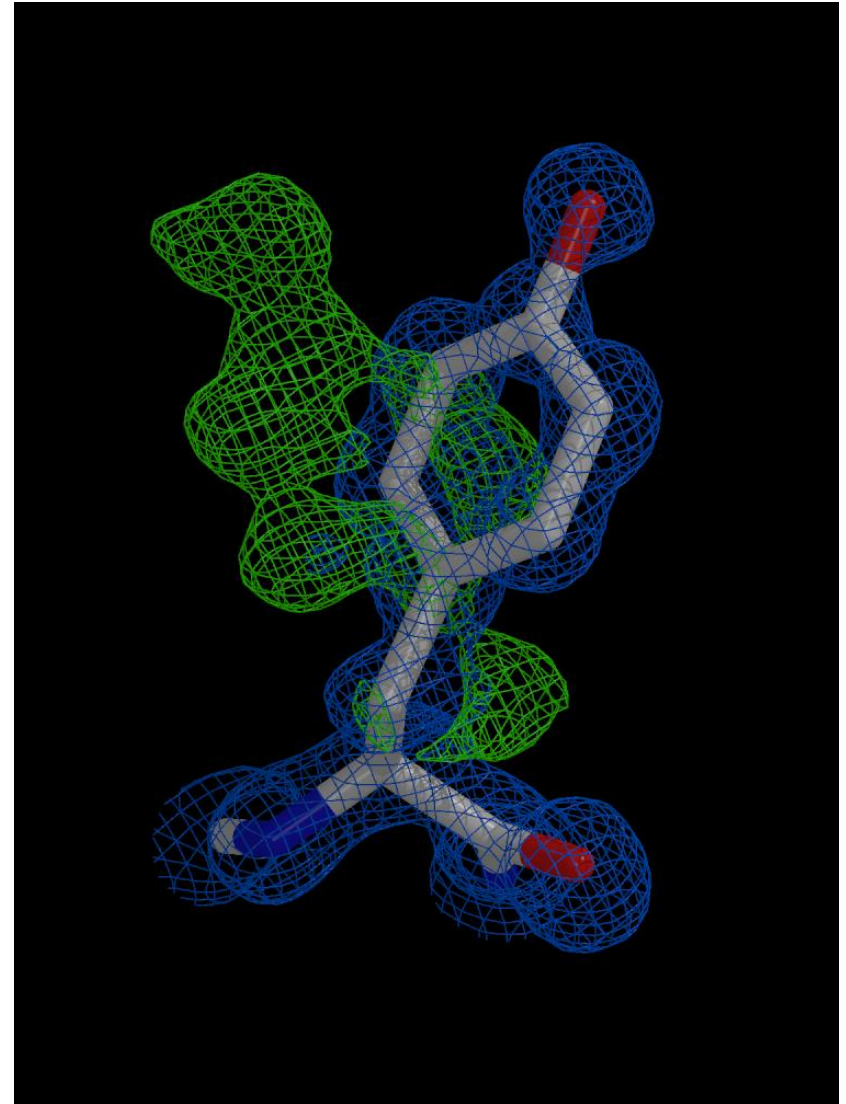

Detailed biological information

The Plan:

- Cryo techniques
 - **Why cool? Radiation damage.**
 - Optimising cryoprotection.
 - Testing at room temperature.
 - Storage and retrieval.
 - If nothing works...

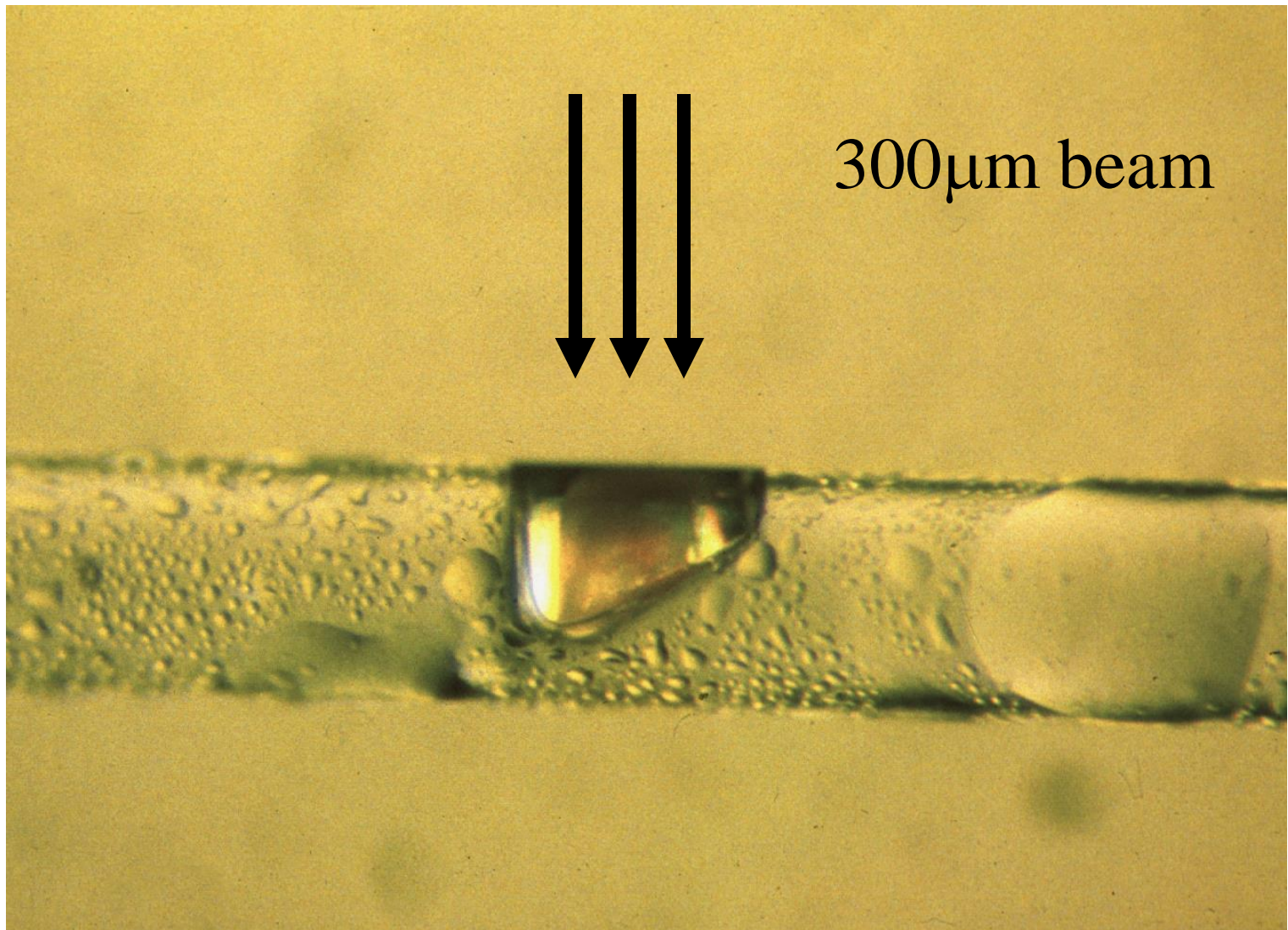

Room temperature: HEWL crystal after 3 hours in a 2nd generation synchrotron beam.

I24, Diamond, *in situ* data collection from a
Bovine Enterovirus 2 crystal, room temperature, 0.5 s
20 μm x 20 μm beam

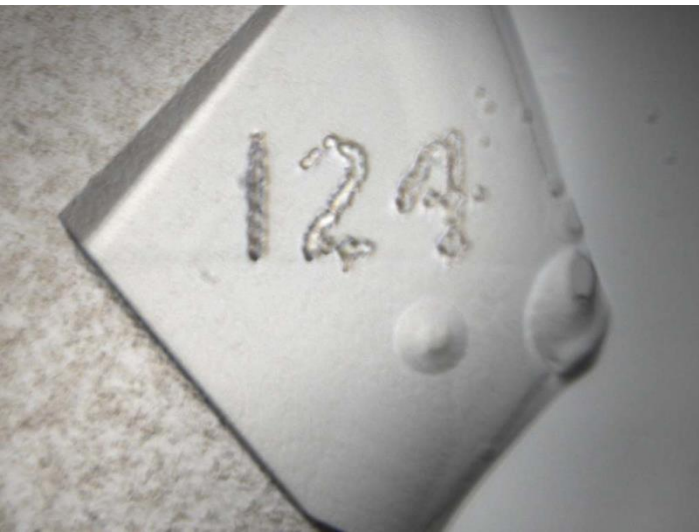
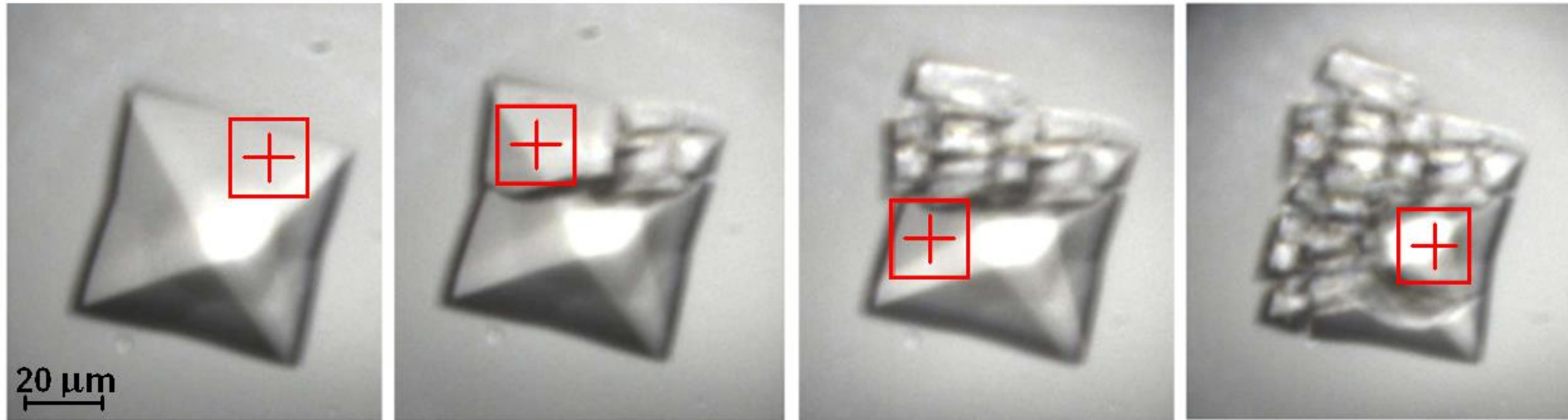

Axford *et al.*,
Acta Cryst D (2012) 592

Beamline logo I24
(Gwyndaf Evans *et al.*)

Radiation Damage

Primary 
Secondary 

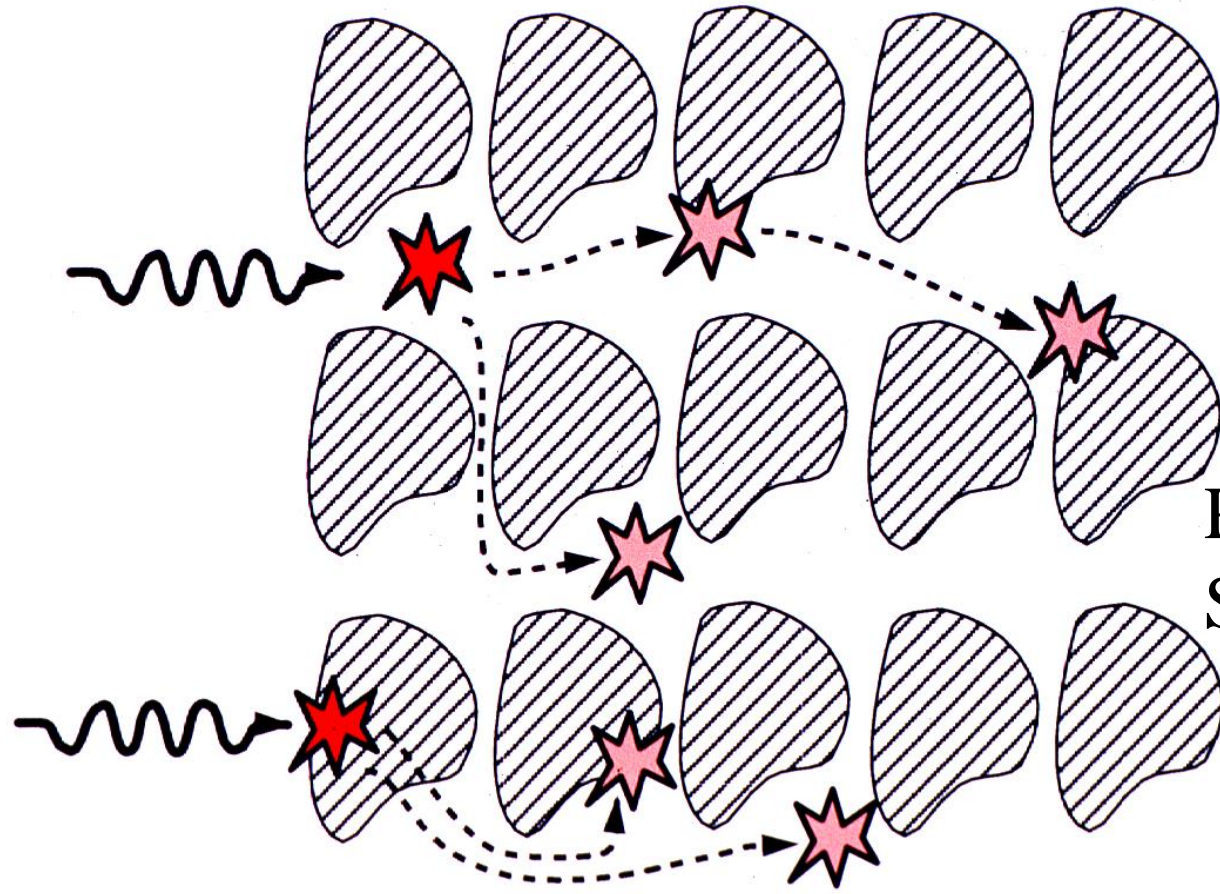

Protein: direct
Solvent: indirect

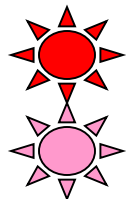

PRIMARY; inevitable, a fact of physics! Neutralise it?



SECONDARY, can we control it?

DECAY OF LDH REFERENCE REFLECTIONS

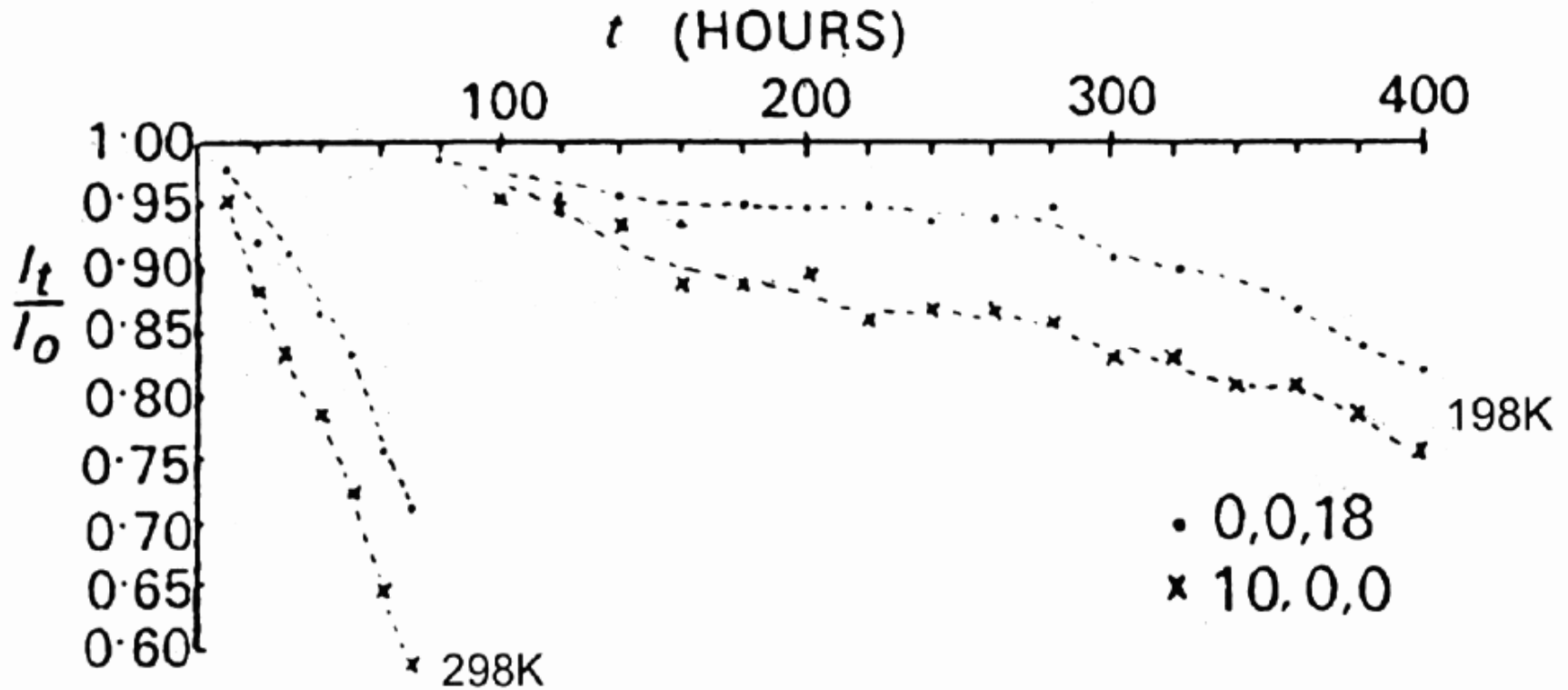

Haas and Rossmann 1970: lactate dehydrogenase

Acta Cryst B26, 998-1004.

ICE a major problem

Loop mounting: T-Y.Teng (1990) J.Appl.Cryst, 23, 387-391.

Used wire loops

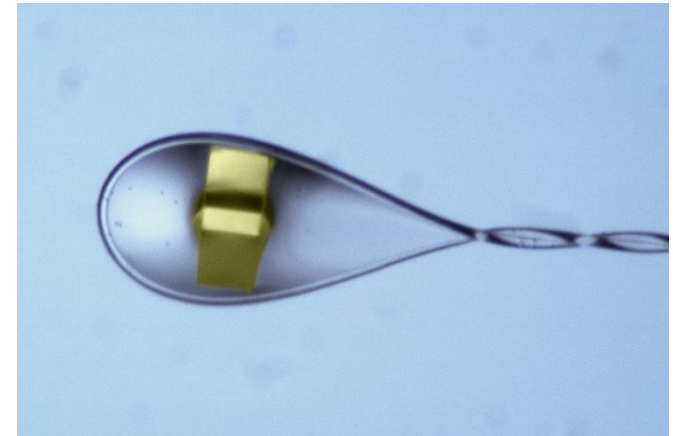
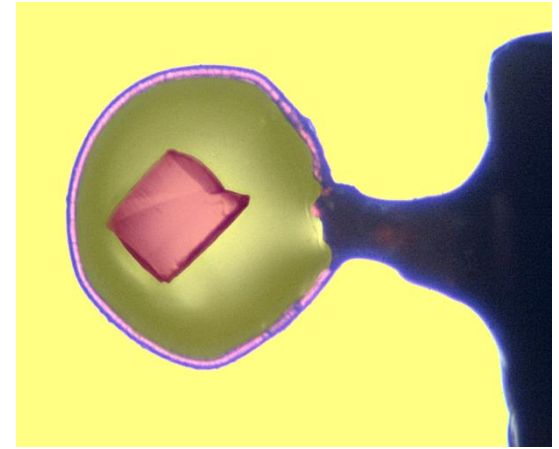
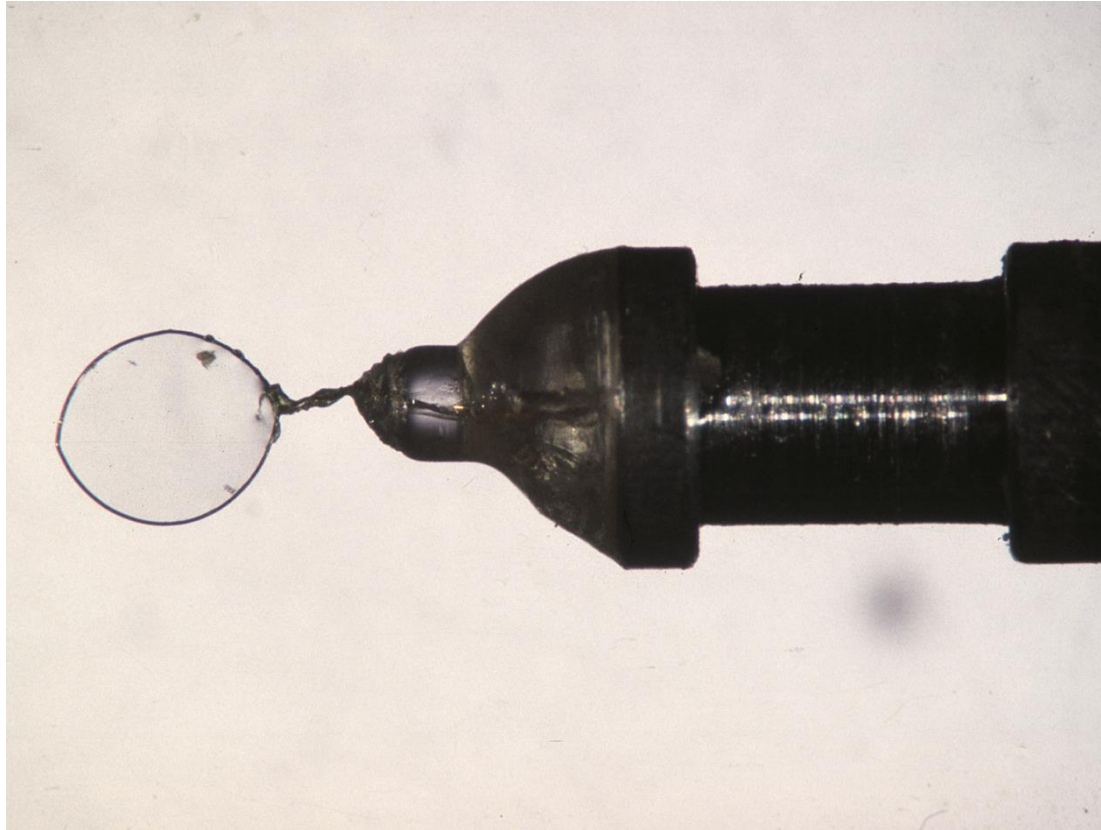

Also, a commercially available and easy to use cryostat (Cosier and Glazer 1986) made the technique accessible to many labs.

[Garman and Schneider, J.Appl.Cryst, (1997) **23**]

Radiation Damage

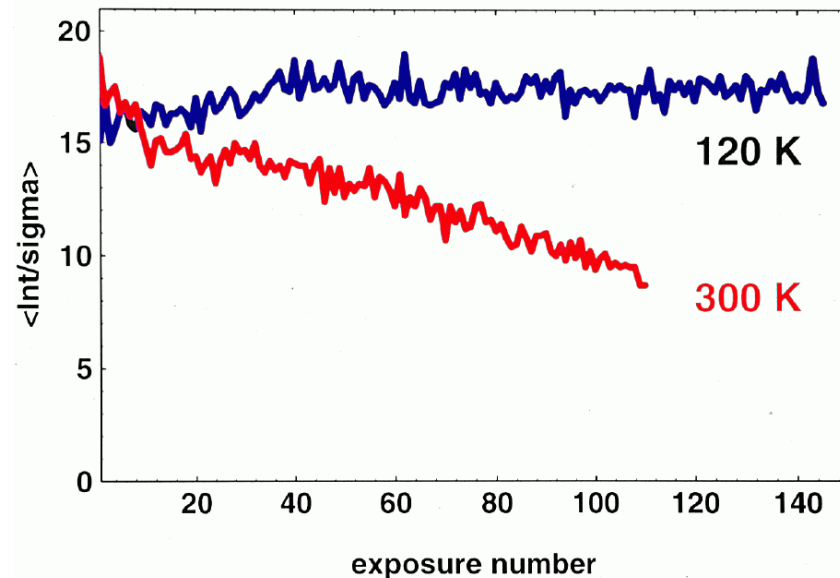
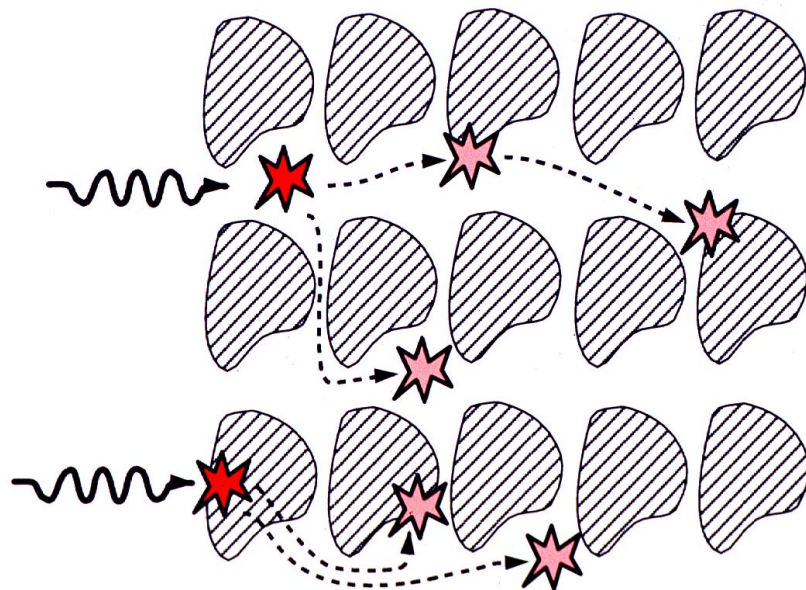

Significantly reduced at
100 K: time factor of ~ 70

[Nave and Garman *JSR* (2005), **12**, 257-260].

SP445: Data Quality

[T.Schneider]

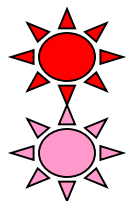
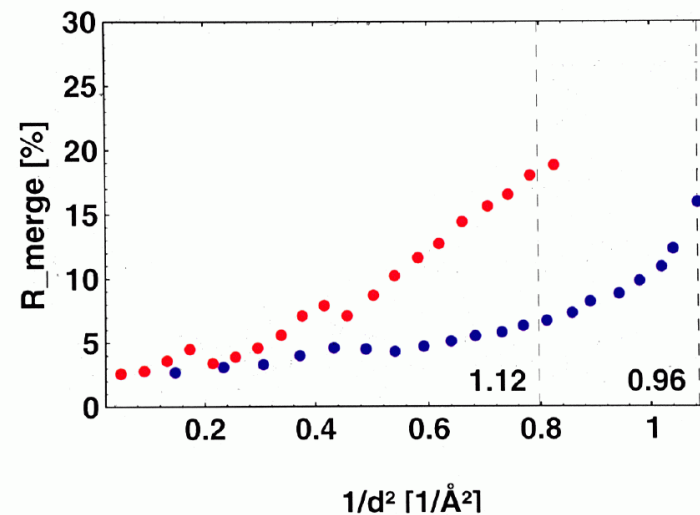

PRIMARY; inevitable, a fact of physics! Proportions?

SECONDARY, can we control it?

Oct 2017, 86% MX PDB < 105 K (91% held below 160 K)

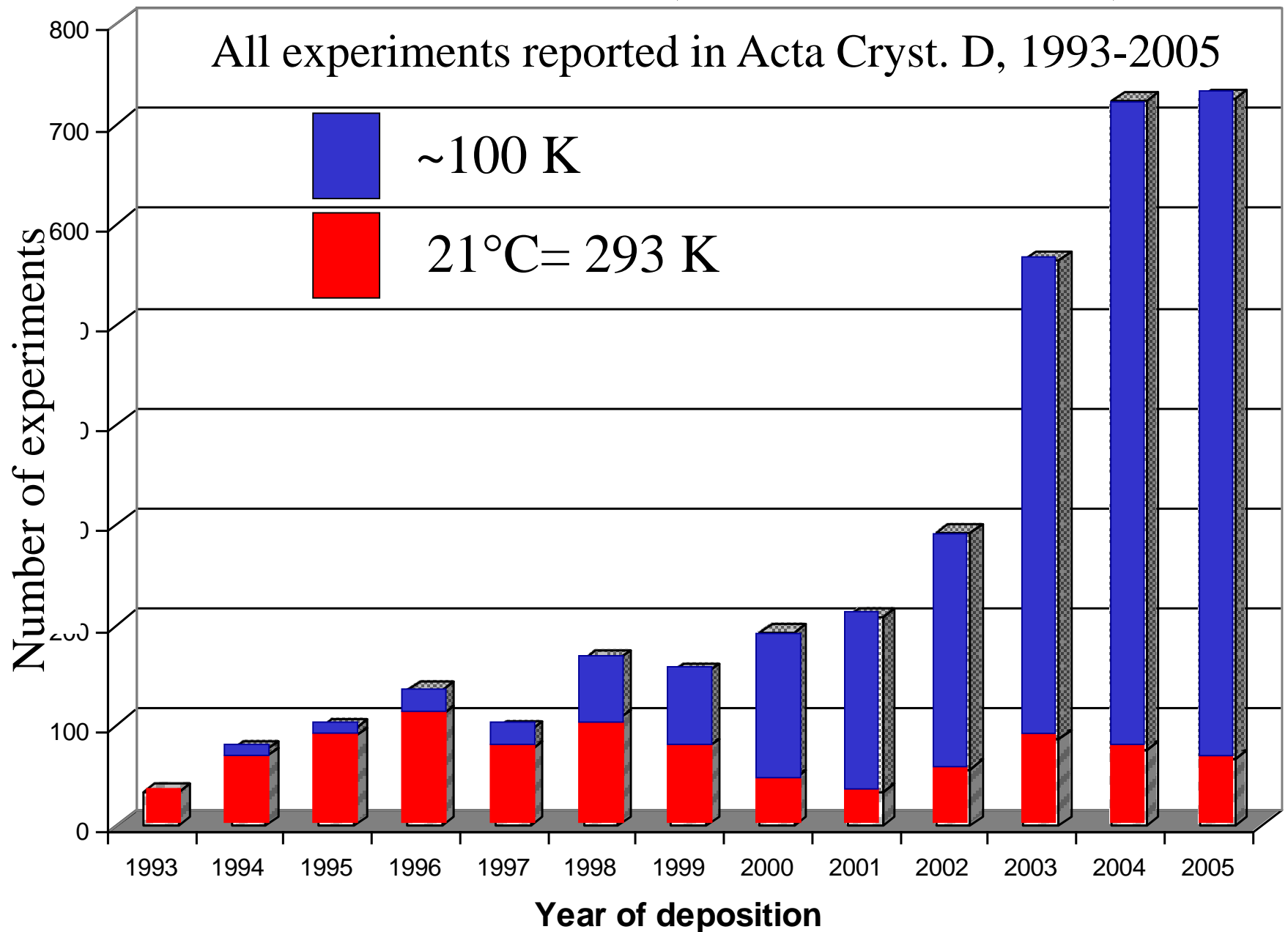

[Garman, in Protein Crystallisation (Ed. T.Bergfors) 2009] Oct 2017, 86% PDB < below 105 K (91% held below 160 K)

Loop mounting is a MUCH
gentler technique than capillary mounting.
e.g. cyclin A, $5\mu\text{m} \times 100\mu\text{m} \times 300\mu\text{m}$

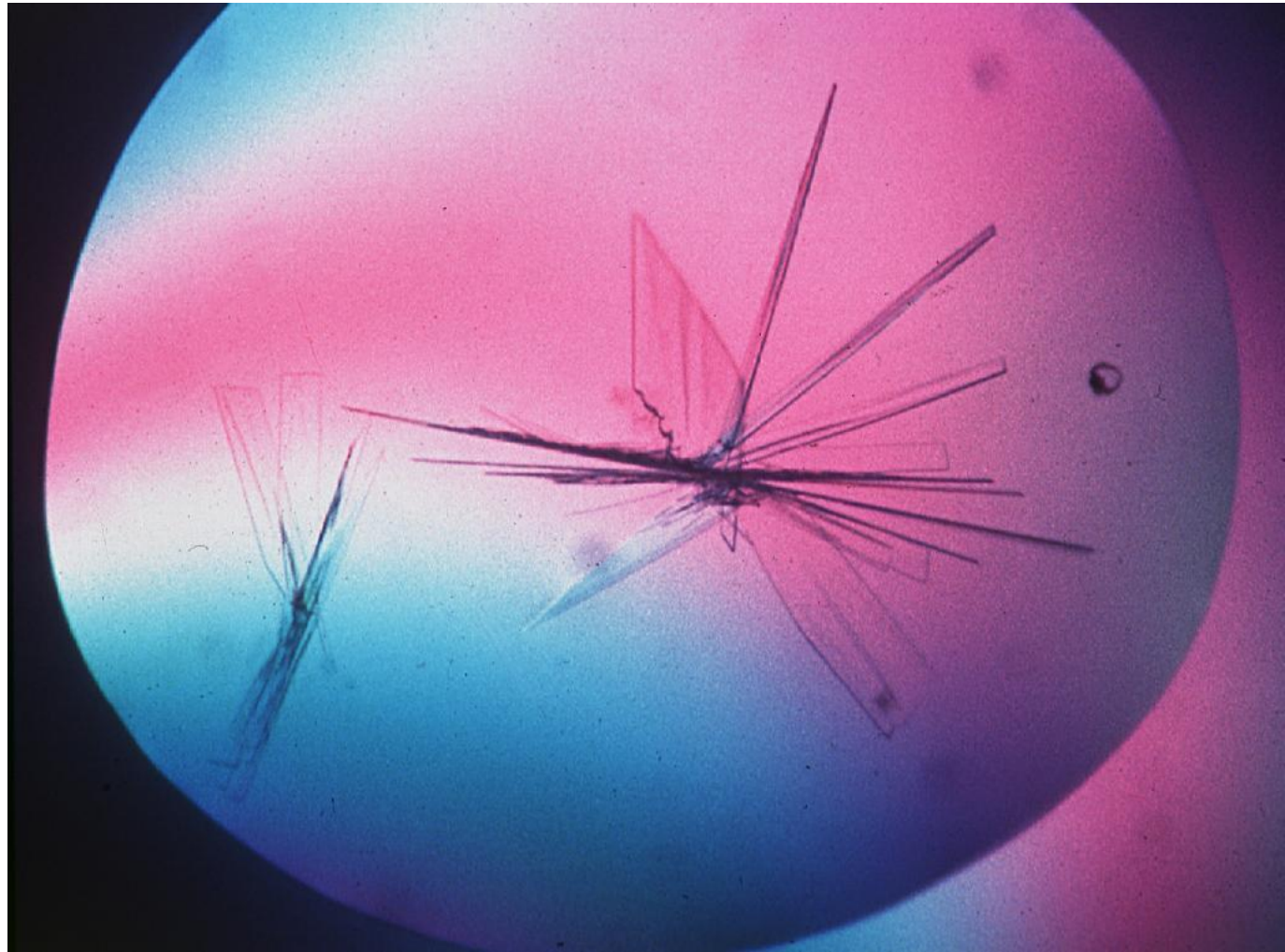

Other advantages:

- Usually get a whole data set from a single crystal \Rightarrow higher QUALITY data.
For MAD, the systematic errors are minimised by using only one crystal.
- Can harvest and store crystals while they are in peak condition.
- Small crystals and flat plates can be mounted easily.
- No secondary radiation damage during storage.
- New experiments are possible.

The Plan:

- Cryo techniques
 - Why cool? Radiation damage.
 - **Optimising cryoprotection.**
 - Testing at room temperature.
 - Storage and retrieval.
 - If nothing works...

Cryocooling: HOW?

- Cool the crystal so fast that the water is vitrified and does not form crystalline ice. [Pure water: $\sim 10^{-5}$ s for typical protein crystal sized drop]
 - Add `antifreeze' to increase time for cooling process. [1-2 s]
i.e. `cryoprotect'
- N.B. WE DO NOT WANT TO 'FREEZE' the crystal!**
- Collect data at around 100K [below 130K and absolutely below 155K [Weik, 2001]]

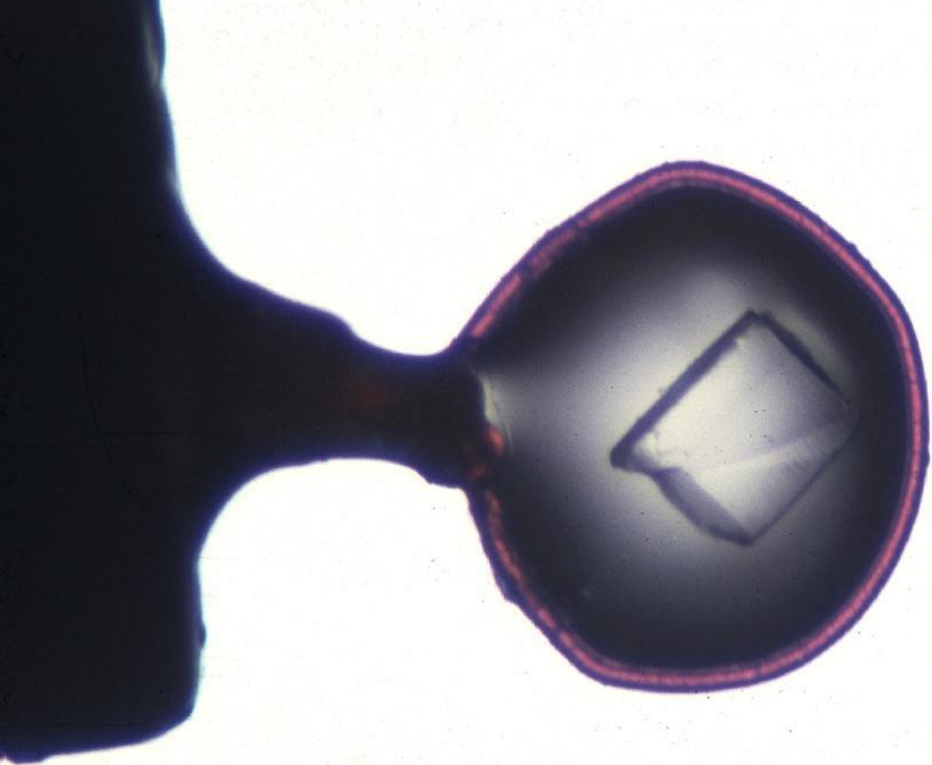

0.8mm

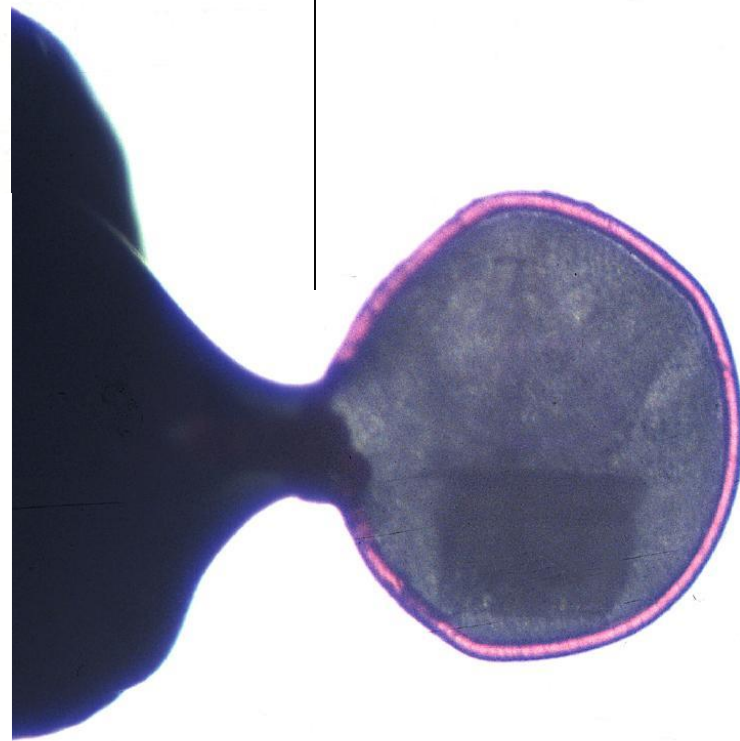

Cryo-buffer optimisation

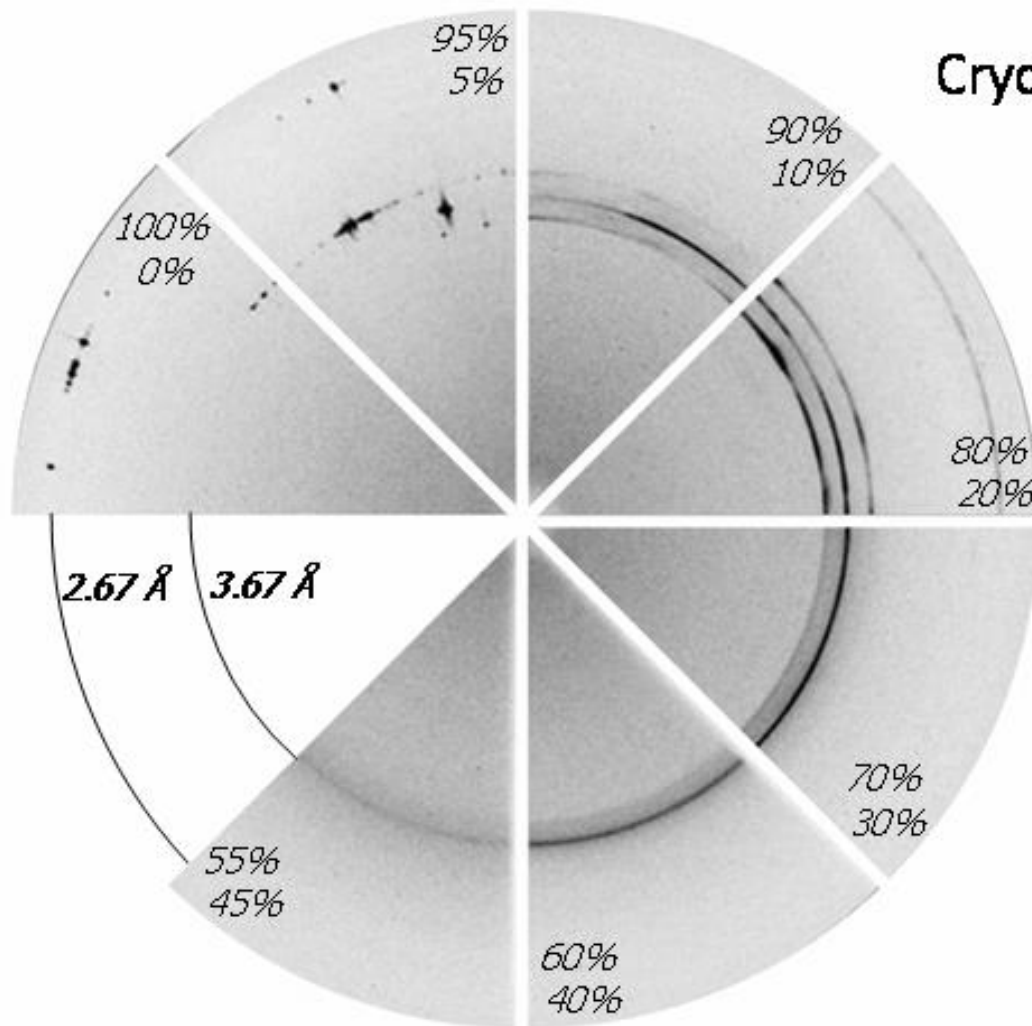

hkl	d(Å)
100	3.9
002	3.67
101	3.44
102	2.67
110	2.25
103	2.07
200	1.95
112	1.92
201	1.88
202	1.72

- replace the water in mother liquor with cryo-agent, rather than diluting the mother liquor.
- test cryo-buffer alone in loop.

Cryo-buffers.

- PEG < 4K → increase PEG, add small PEGs
- PEG ≥ 4K → add small PEGs
- 2/3rds of cases → add 15 - 25% glycerol
- MPD → harvesting buffer, increase MPD concentration.
- Salt → add MPD and/or ethylene glycol or glycerol
→ increase conc/add salt. Lithium salts good.
[Rubinson et al, Acta D (2000), D56, 996-1001.]
→ Exchange salt. e.g. 100% 8M Na Formate.

N.B. Low salt needs > concentration of cryoprotectant than high salt.

Sugars, paratone N, combinations, +++

CRYSTAL MANIPULATION:

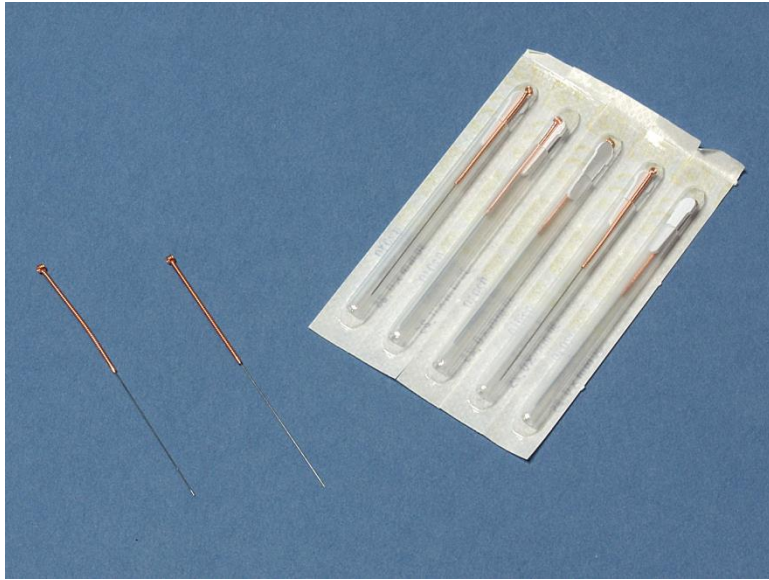

Acupuncture needles:
[free samples available from me]

- No loss of liquid
- Slightly flexible
- Fine
- Different sizes available.

e.g. 'Skin' on protein drop:

Gentle surgery

Skin doesn't diffract: just
increases background

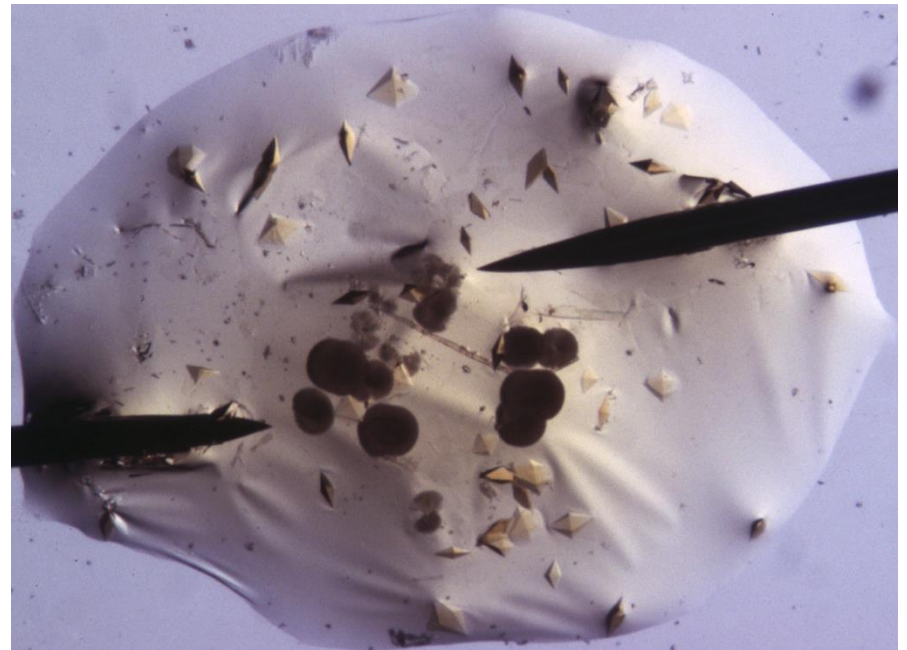

Cats' whiskers, horse eye lashes, horse tail hairs, etc etc

Manipulation of crystal from growth drop. A cryo-loop, or a syringe with flexible hose give much better control than a Gilson.

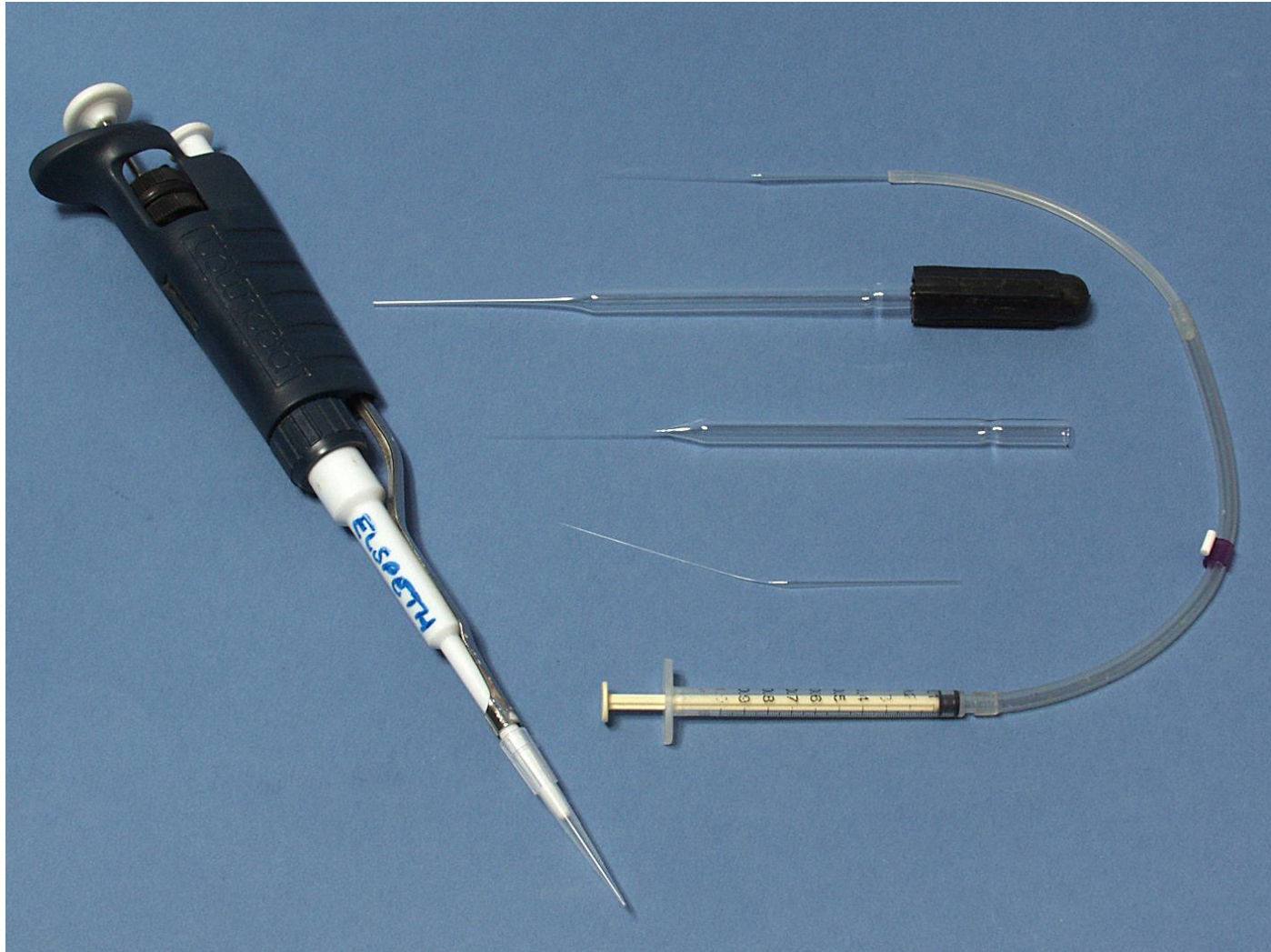





Ellie
2002-2009

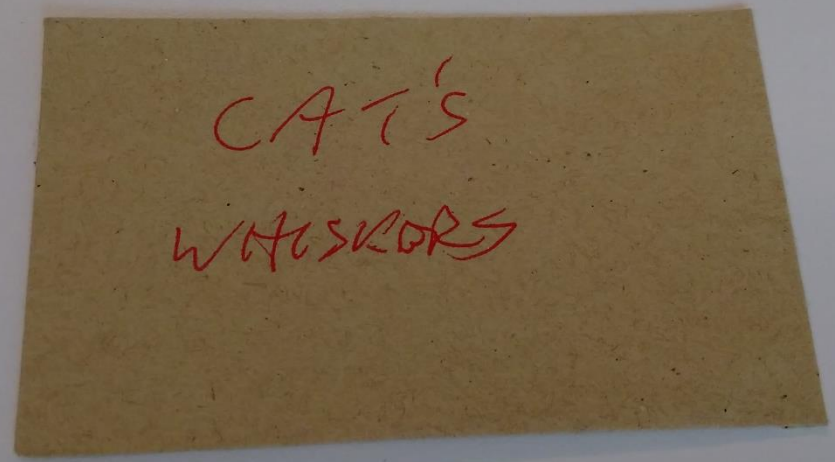

Megan, 1988-2017

TABLE 1. Minimum concentration of glycerol to be added to solutions 1 to 50 of the Hampton Research Crystal Screen^(TM) I Reagent Components to provide cryoprotection when frozen to 100K. It must be noted that glycerol was added to the Crystal Screen solutions resulting in a DILUTION of the original components. From Garman and Mitchell J. Appl. Cryst. (1996) 29, 584-587

Solution number, SALT	BUFFER	PRECIPITANT	GLYCEROL CONC. v/v
1. 0.02 M Ca Chloride	0.1 M Na Acetate pH 4.6	30% v/v 2-methyl-2,4-pentanediol	0
2. None	None	0.4 M K ₂ Na Tartrate	35
3. None	None	0.4 M NH ₄ Phosphate	35
4. None	0.1 M Tris HCl pH 8.5	2.0 M NH ₄ Sulphate	25
5. 0.2 M Na Citrate	0.1 M Na Hepes pH 7.5	30% v/v 2-methyl-2,4-pentanediol	0
6. 0.2 M Mg Chloride	0.1 M Tris HCl pH 8.5	30% w/v PEG 4000	20
7. None	0.1 M Na Cacodylate pH 6.5	1.4 M Na Acetate	30
8. 0.2 M Na Citrate	0.1 M Na Cacodylate pH 6.5	30% v/v 2-propanol	30
9. 0.2 M NH ₄ Acetate	0.1 M Na Citrate pH 5.6	30% w/v PEG 4000	15
10. 0.2 M NH ₄ Acetate	0.1 M Na Acetate pH 4.6	30% w/v PEG 4000	15
11. None	0.1 M Na Citrate pH 5.6	1.0 M NH ₄ Phosphate	30
12. 0.2 M Mg Chloride	0.1 M Na Hepes pH 7.5	30% v/v 2-propanol	10
13. 0.2 M Na Citrate	0.1 M Tris HCl pH 8.5	30% v/v PEG 400	0
14. 0.2 M Ca Chloride	0.1 M Na Hepes pH 7.5	28% v/v PEG 400	5
15. 0.2 M NH ₄ Sulphate	0.1 M Na Cacodylate pH 6.5	30% w/v PEG 8000	15
16. None	0.1 M Na Hepes pH 7.5	1.5 M Li Sulphate	25
17. 0.2 M Li Sulphate	0.1 M Tris HCl pH 8.5	30% PEG 4000	15
18. 0.2 M Mg Acetate	0.1 M Na Cacodylate pH 6.5	20% PEG 8000	20
19. 0.2 M NH ₄ Acetate	0.1 M Tris HCl pH 8.5	30% v/v 2-propanol	20
20. 0.2 M NH ₄ Sulphate	0.1 M Na Acetate pH 4.6	25% w/v PEG 4000	20
21. 0.2 M Mg Acetate	0.1 M Na Cacodylate pH 6.5	30% v/v 2-methyl-2,4-pentanediol	0
22. 0.2 M Na Acetate	0.1 M Tris HCl pH 8.5	30% w/v PEG 4000	15
23. 0.2 M Mg Chloride	0.1 M Na Hepes pH 7.5	30% v/v PEG 400	0
24. 0.2 Ca Chloride	0.1 M Na Acetate pH 4.6	20% v/v 2-propanol	30
25. None	0.1 M Imidazole pH 6.5	1.0 M Na Acetate	30
26. 0.2 M NH ₄ Acetate	0.1 M Na Citrate pH 5.6	30% v/v 2-methyl-2,4-pentanediol	0
27. 0.2 M Na Citrate	0.1 M Na Hepes pH 7.5	20 % v/v 2-propanol	30
28. 0.2 M Na Acetate	0.1 M Na Cacodylate pH 6.5	30% w/v PEG 8000	15
29. None	0.1 M Na Hepes pH 7.5	0.8 M K ₂ Na Tartrate	35
30. 0.2 M NH ₄ Sulphate	None	30% w/v PEG 8000	15
31. 0.2 M NH ₄ Sulphate	None	30% w/v PEG 4000	15
32. None	None	2.0 M NH ₄ Sulphate	25
33. None	None	4.0 M Na Formate	10
34. None	0.1 M Na Acetate pH 4.6	2.0 M Na Formate	30
35. None	0.1 M Na Hepes pH 7.5	1.6 M Na ₂ K Phosphate	25
36. None	0.1 M Tris HCl pH 8.5	8% w/v PEG 8000	35
37. None	0.1 M Na Acetate pH 4.6	8% w/v PEG 4000	30
38. None	0.1 M Na Hepes pH 7.5	1.4 M Na Citrate	10
39. None	0.1 M Na Hepes pH 7.5	2% v/v PEG 400 and 2.0 M NH ₄ Sulphate	15
40. None	0.1 M Na Citrate pH 5.6	20% v/v 2-propanol and 20% w/v PEG 4000	5
41. None	0.1 M Na Hepes pH 7.5	10% v/v 2-propanol and 20% w/v PEG 4000	15
42. 0.05 M K Phosphate	None	30% w/v PEG 8000	20
43. None	None	30% v/v PEG 1500	20
44. None	None	0.2 M Mg Formate	50
45. 0.2 M Zn Acetate	0.1 M Na Cacodylate pH 6.5	18% w/v PEG 8000	20
46. 0.2 M Ca Acetate	0.1 M Na Cacodylate pH 6.5	18% w/v PEG 8000	20
47. None	0.1 M Na Acetate pH 4.6	2.0 M NH ₄ Sulphate	20
48. None	0.1 M Tris HCl pH 8.5	2.0 M NH ₄ Phosphate	20
49. 1.0 M Li Sulphate	None	2% w/v PEG 8000	20
50. 0.5 M Li Sulphate	None	15% w/v PEG 8000	20

Illegible table of minimum concentrations of glycerol required to cryoprotect Hampton Screen I.

For emergency use only (done by dilution)

[Mitchell and Garman, J.Appl.Cryst. (1996) 29, 584
McFerrin and Snell J.Appl.Cryst (2002) 35, 538]

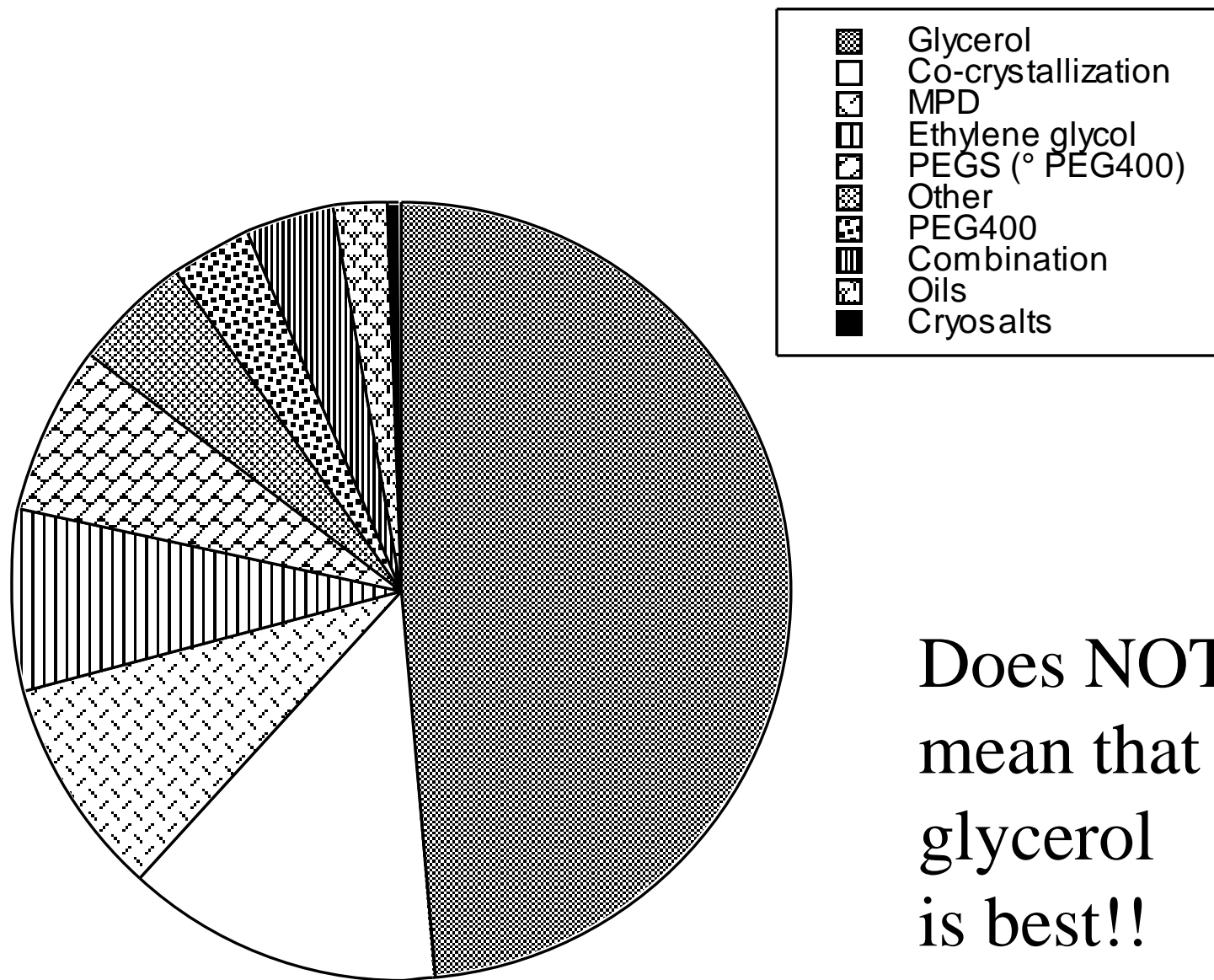

Does NOT
mean that
glycerol
is best!!

Acta D structures 2001. [Garman and Doublé, Methods in Enzymology

2003, 368, 188.]

Transfer of crystal into cryobuffer:

1) Dialysis of cryoprotectant.

[Fernandez *et al*, JAPC (2000) 33, 168-171]

2) Co-crystallisation with cryoprotectant agent:

glycerol is already known to help in some cases

[Sousa, Acta Cryst D51 (1995) 271-277.]

3) Rapid transfer

- Straight into final concentration for up to 5 mins
- can just 'sweep through' - 0.5 sec
- Sequential soaks in increasing concentrations.

WANT TO MINIMISE HANDLING, as handling can increase the mosaic spread. i.e. 2) is BEST:.....

SOLUBILITY versus OSMOTIC shock

Crystal transfer optimisation:

- balance osmotic shock and attack of crystal surface
- serial transfers: minimise handling and dehydration

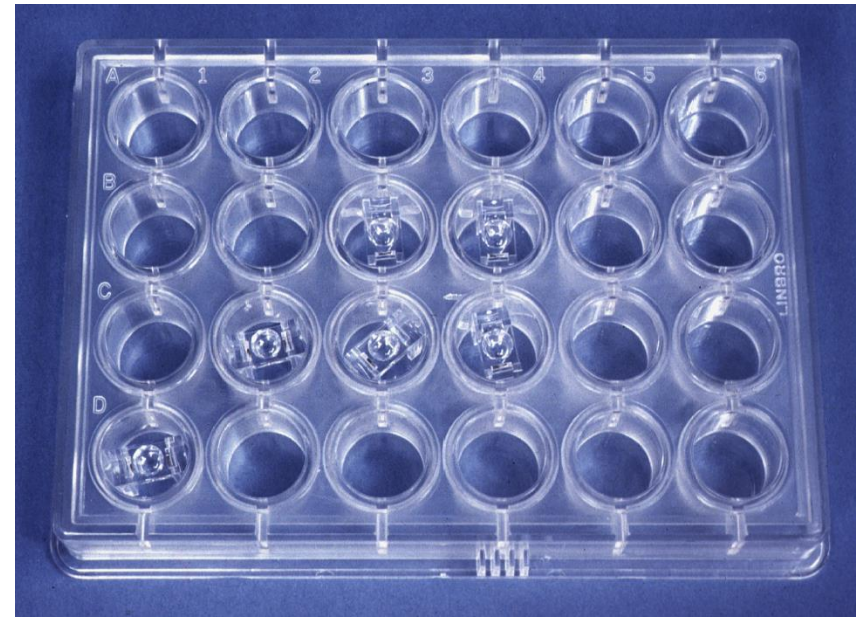

Quick 'dunk': 3.2 Å N6 influenza NA

a) Move crystal between solutions

2.4 Å N6 influenza NA

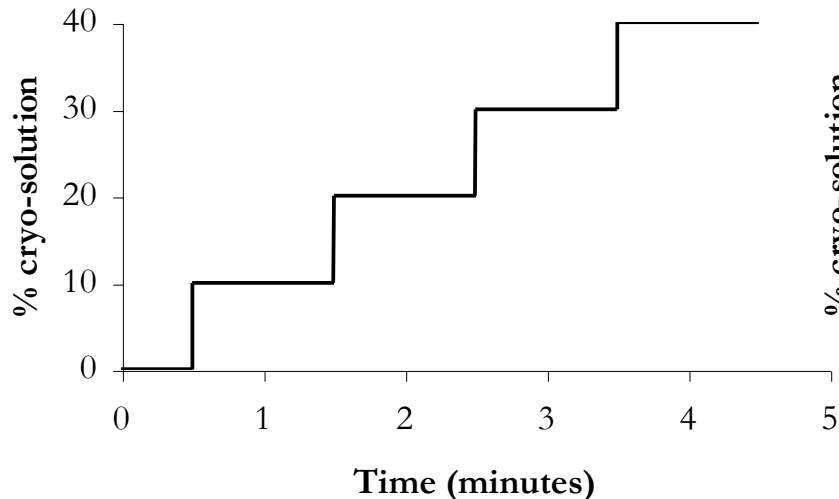

b) Solution pipetted onto crystal

1.6 Å N6 influenza NA

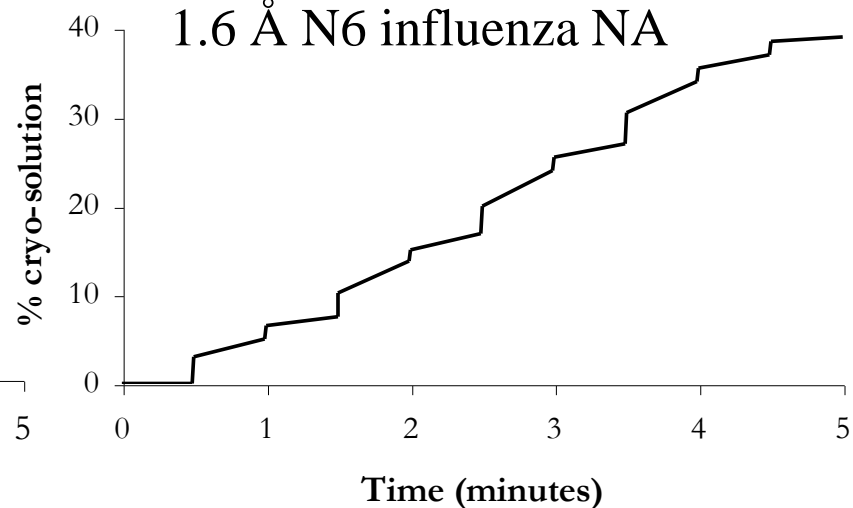

Hardware development: standardisation...



a



b



c



d



10mm



Rayon loops
**Hampton
Research**

Litho-loops,
etched mylar,
ActiLoop polymer
Molecular Dimensions

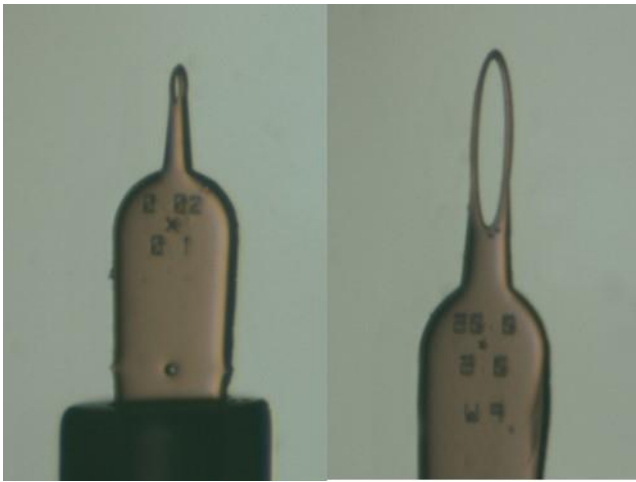

Micro-mounts,
microfabricated
polyimide film. **MiTeGen**
[Thorne *et al* (2003), JAPC 36, 1455.]



Fishing:

- minimise handling
- minimise liquid round crystal
- fish near cryogen
- loop perpendicular to liquid

N.B. Acupuncture needles.
Salt crystals in loop.

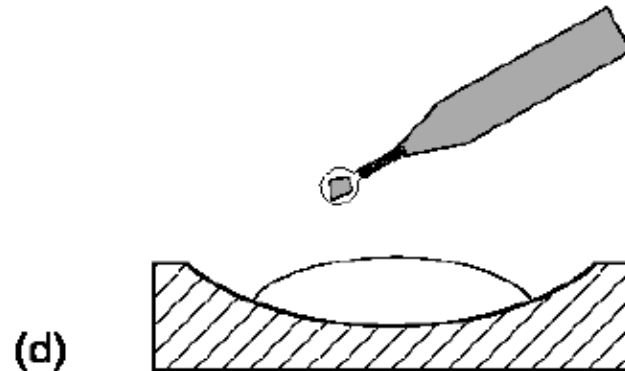
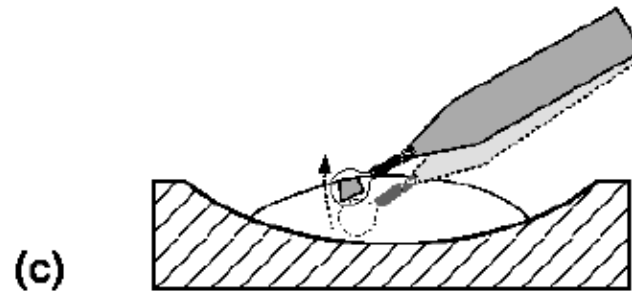
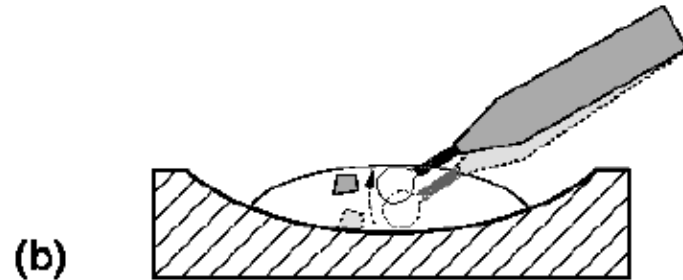
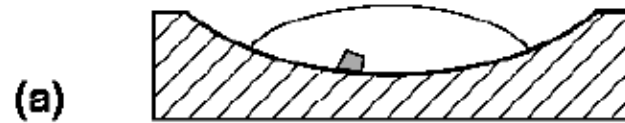

Flash cool into cryogen:

- Straight into liquid nitrogen:
**have a standard pin length AND
blow/flap away surface cold nitrogen
from FULL Dewar.**
- Stream cool into nitrogen gas stream held
at around 100K: pre-align pin.
have a standard pin length!

PRACTICE!!!

(but not with your most precious crystals)

Humidity device to avoid dehydration during mounting

Especially effective for those mother liquors which phase separate when crystallisation drop is opened.



[Farley et al., Juers *Acta Cryst D* (2014) 70:2111-24]

Figure 1

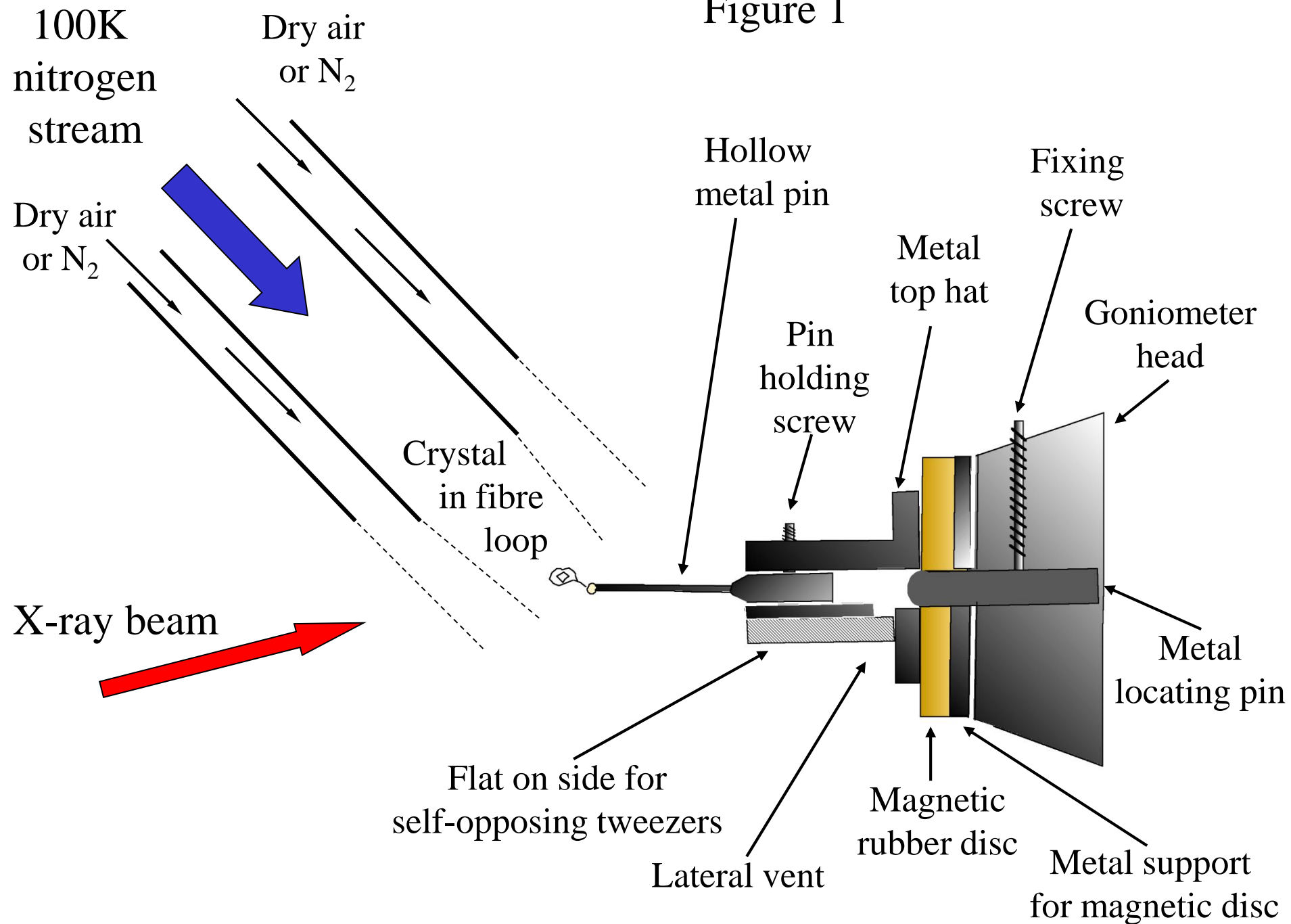

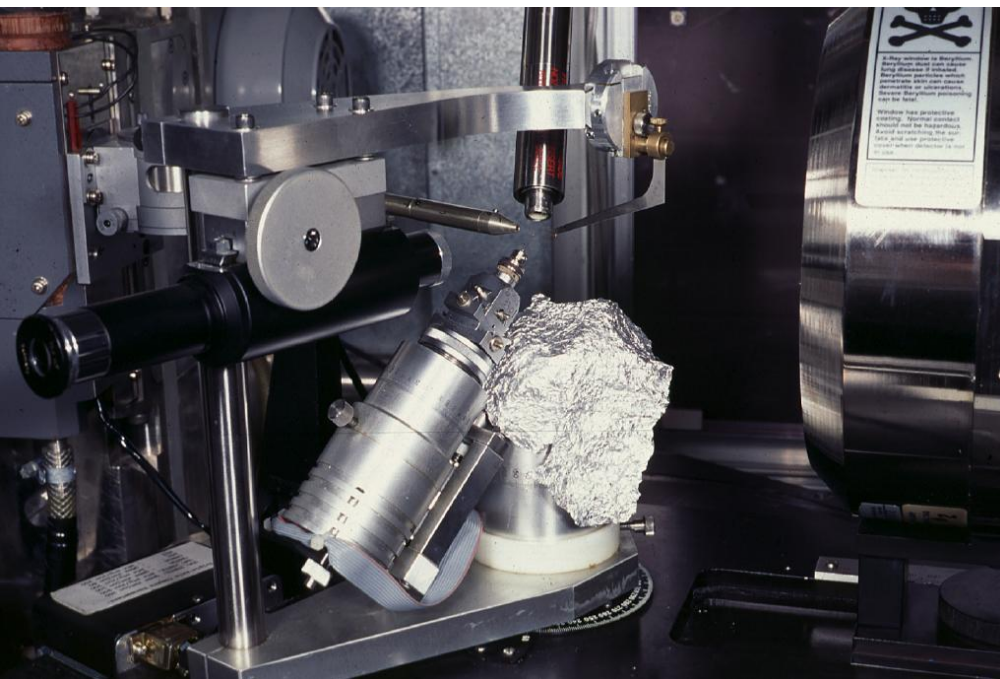
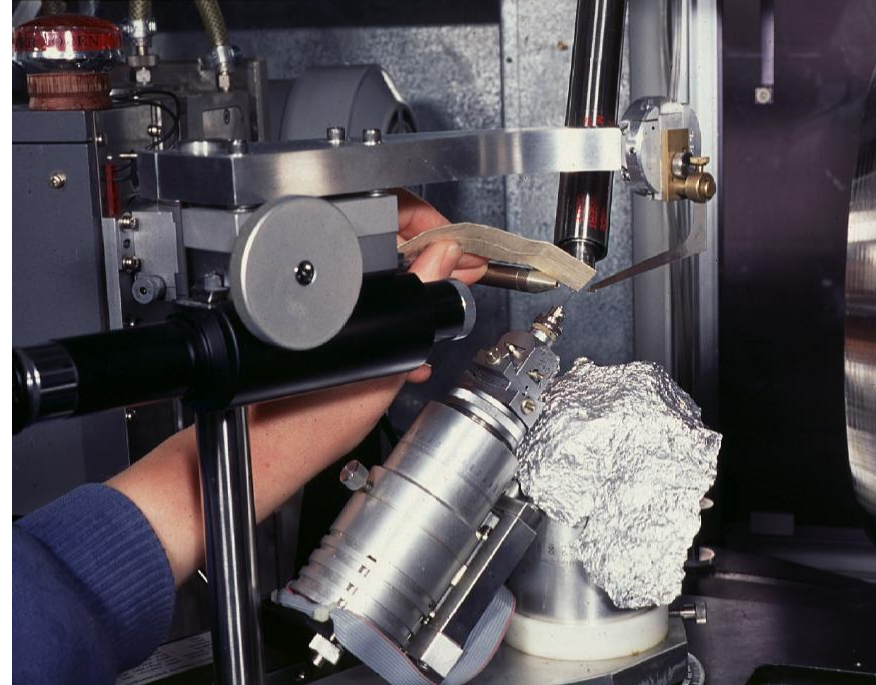

- Pre-centre loop.
- Speed of transfer from drop
- Block stream [avoid dehydration]
- Speed of cooling

Why bother to cover the nitrogen stream?

- Avoid crystal being dehydrated by dry nitrogen/air.
- You may wave crystal in and out of stream while cooling it: slow cooling will give ice.
- Want to cool it FAST. Much easier to do that if you whip the cover away once crystal is in position.

DIFFRACTION?

- NO ...

Does the crystal diffract at room temperature??

NO



Back to crystallisation
trials

YES



Change cryo-protocol

- YES... then take data and/or store it in a Dewar.

The Plan:

- Cryo techniques
 - Why cool? Radiation damage.
 - Optimising cryoprotection.
 - **Testing at room temperature.**
 - Storage and retrieval.
 - If nothing works...

(Much) easier RT mounting method

Allows protein crystals to be mounted at room temperature in loop.

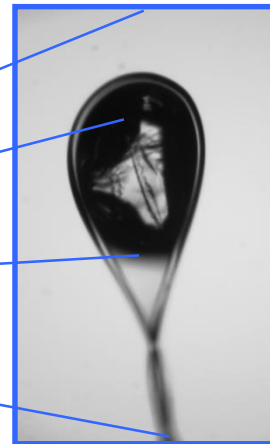
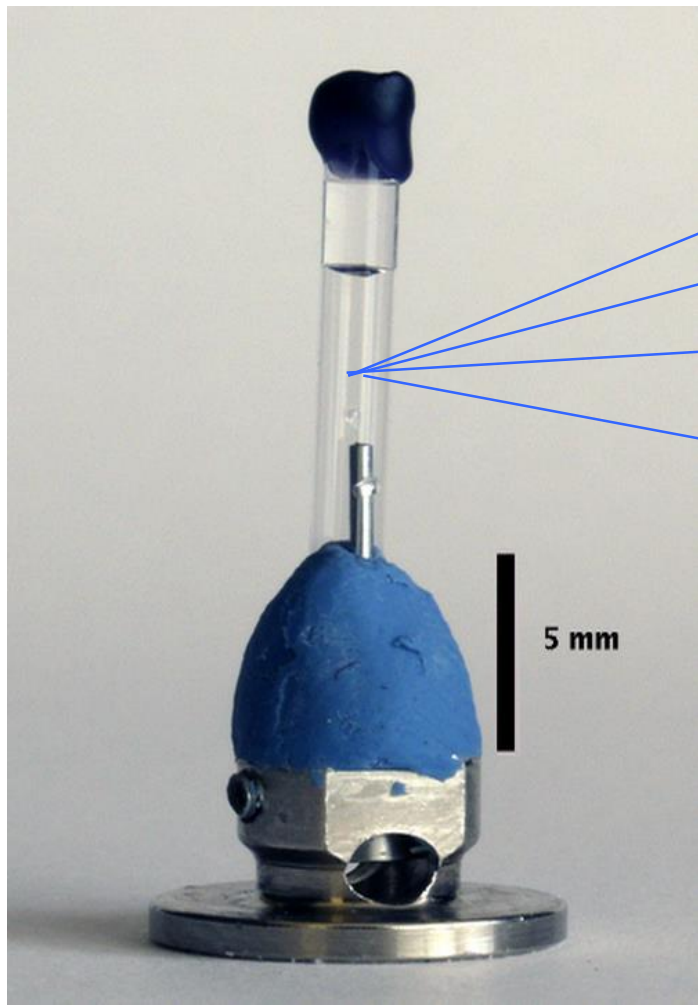

Capillary prevents drop drying out at room temperature.

Also eliminates crystal manipulation between room temperature and cryo-cooled datasets.

Skrzypczak-Jankun *et al* Acta. Cryst. (1996).
D52, 959-965

Room temperature crystal mounting methods

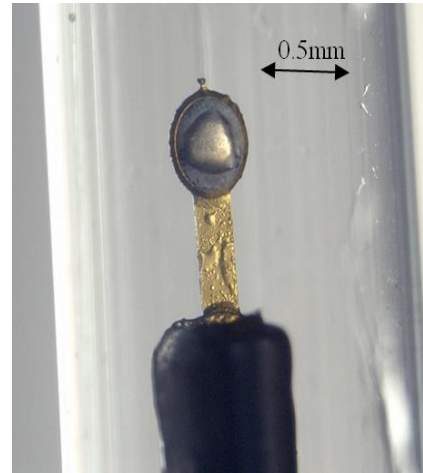
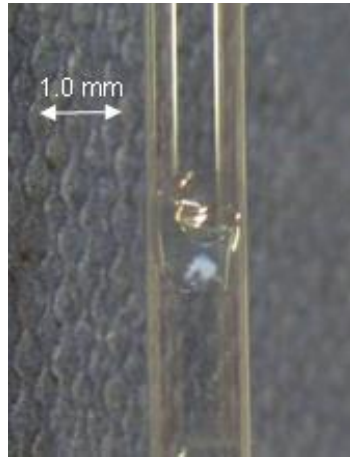
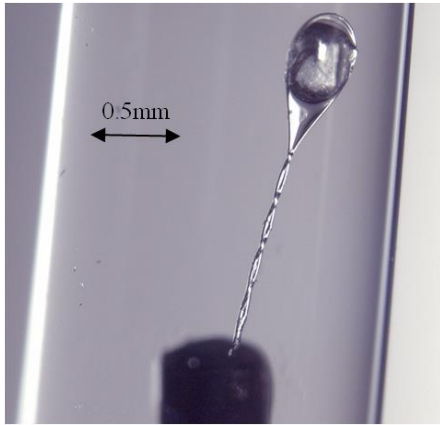

MiTeGen

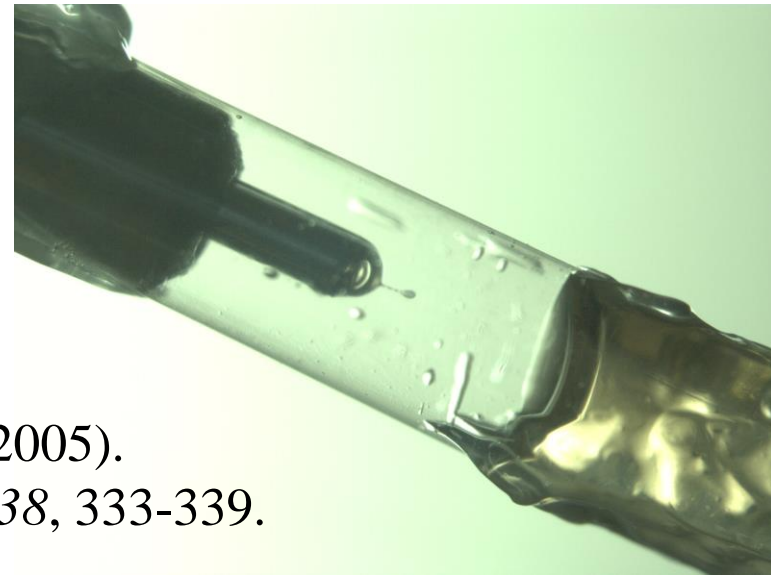

Kalinin *et al.* (2005).
J. App. Cryst. 38, 333-339.

MOSAICITY:

- Want to minimise mosaicity but it often increases.
- Are cryoconditions optimised?
 - solutions
 - transfer
- Speed of transfer to cryogen
- Speed of cooling
- Size of crystal:

Should be able to reproduce room temp mosaicity [need to know it!].

Minimise mosaic spread to optimise data quality.

Should be able to reproduce room temp mosaicity [need to know it!].

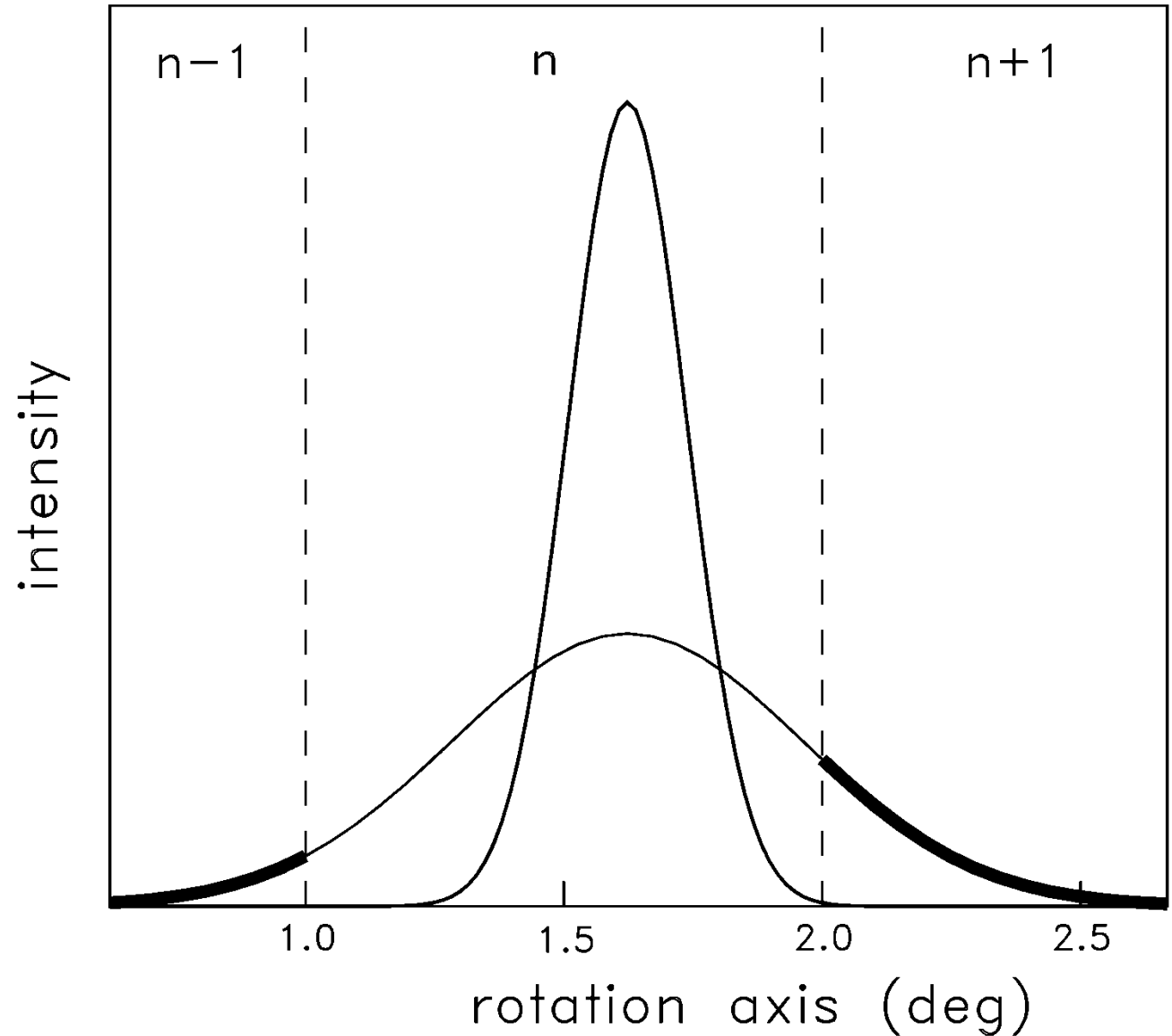

Cryo-protocol Optimisation: maximising resolution, [minimise mosaicity]

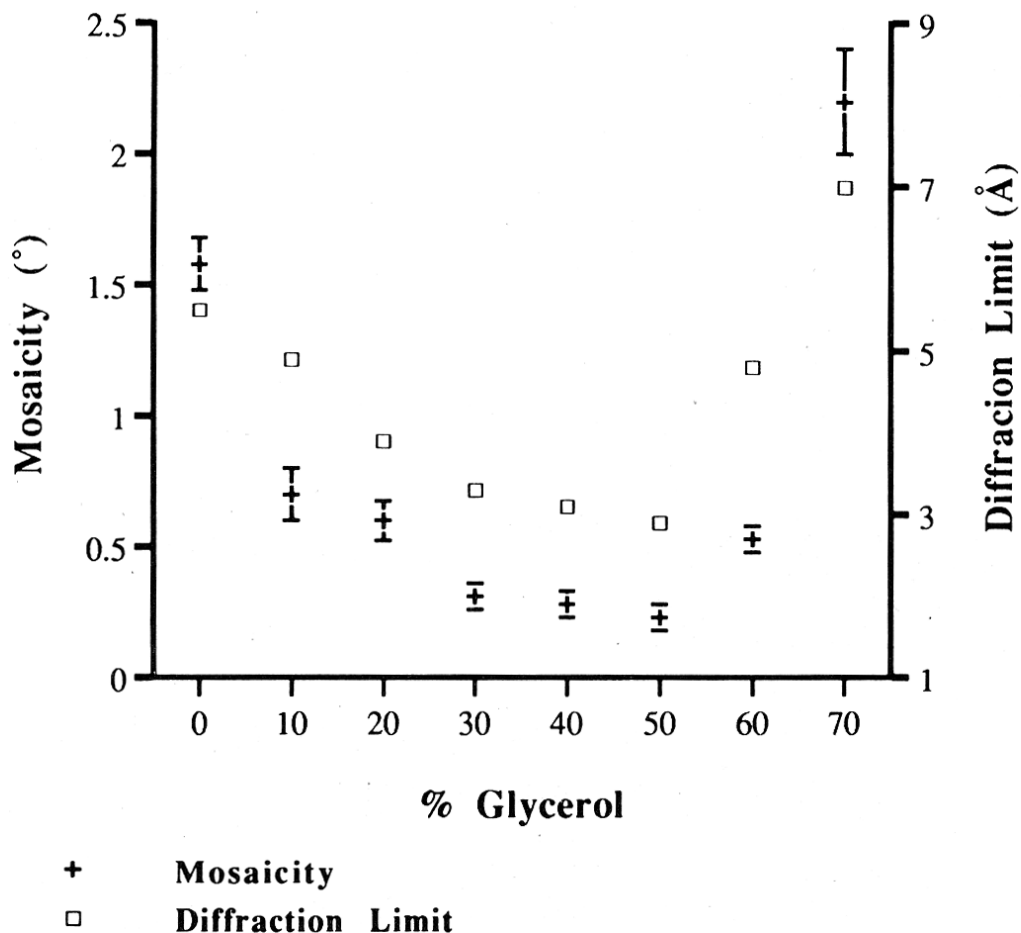

Fig. 2. Variation of mosaicity and diffraction limit of GPb crystals with percentage of glycerol in the buffer. The error bars represent statistical counting errors only.

The Plan:

- Cryo techniques
 - Why cool? Radiation damage.
 - Optimising cryoprotection.
 - Testing at room temperature.
 - **Storage and retrieval**
 - If nothing works...

Crystal
storage
and
retrieval

Copyrighted Farside cartoon of freezer full of frozen heads and man tripping over cable.

Hyperquenching: want a FAST cool

Keep Dewar full or remove gas layer from above liquid.

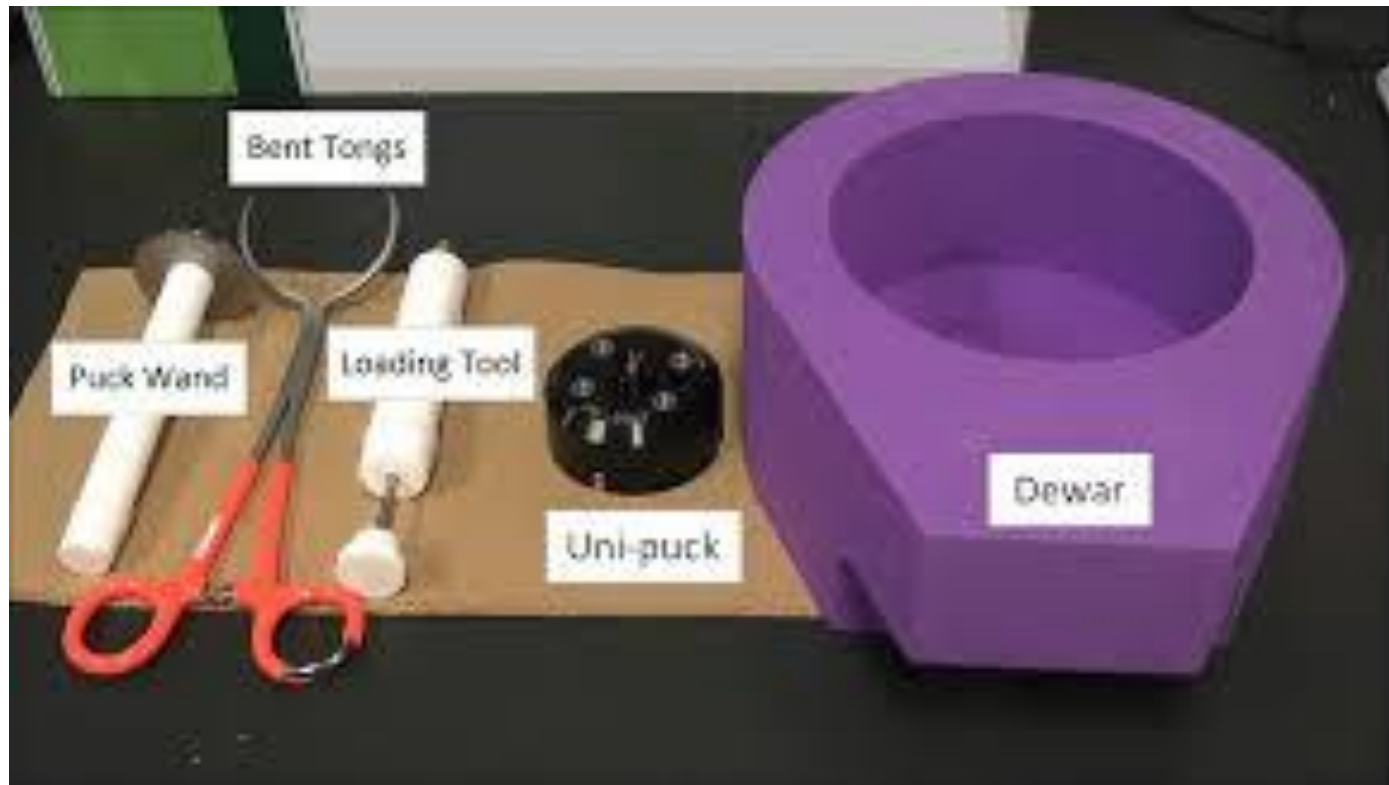

[Warkentin et al., Thorne, J. Appl. Cryst. (2006) 39, 805]



STORAGE:

- Label the vials beforehand.
- Label the canes.
- Allow transport Dewars to dry out after each trip.



Dewar drying rack, Dept Biochemistry, Oxford, UK



Excellent Dewar testing protocol

<http://smb.slac.stanford.edu/facilities/hardware/cryotools/shipping-dewar-testing.html>

GOOGLE search (first hit):

ssrl dewar testing

[See also Owen, Pritchard & Garman. *J. Appl. Cryst.* (2004) **37**, 1000-1003]

Change storage LN₂ every 3 months.



c)

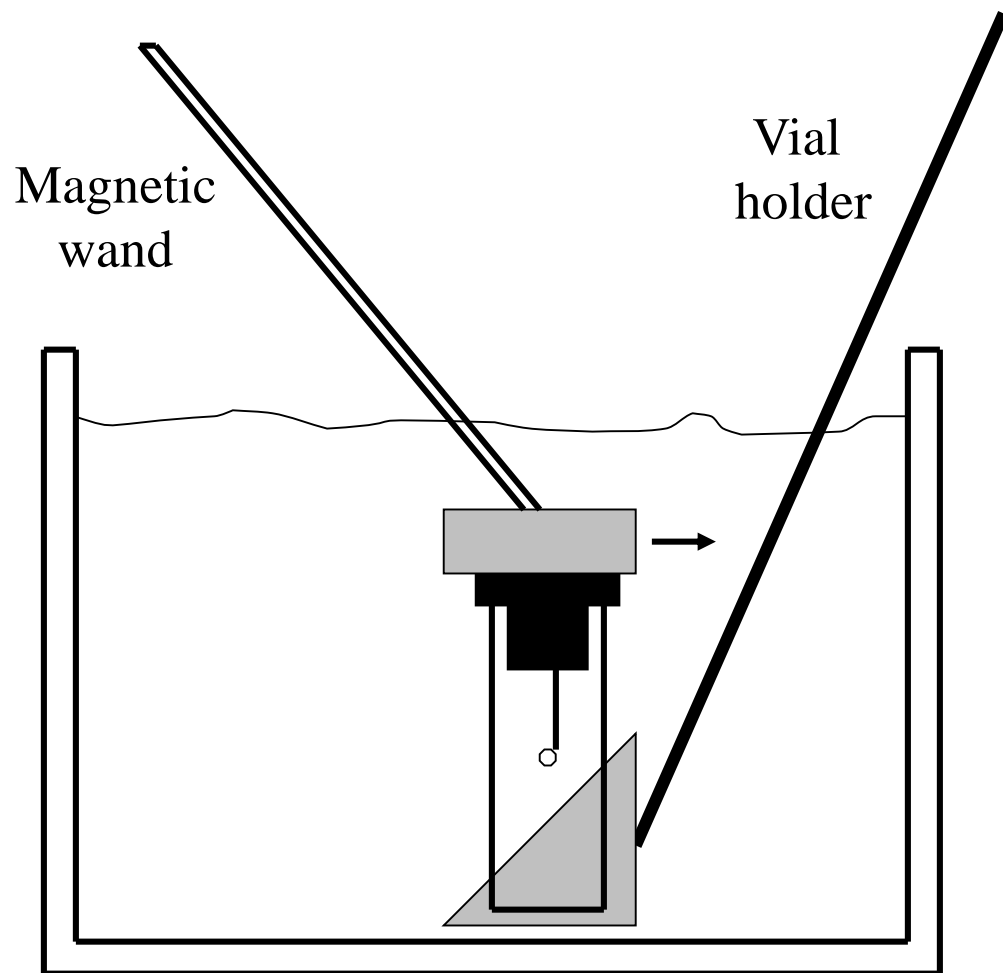

Crystal Handling under LN2

- Use appropriate tools
- Have a small working Dewar: change the LN2 in it often.
- Wait for LN2 to stop bubbling before trying any manipulations.
- Only move one hand at a time
- Steady the stationary hand on edge of Dewar

Step by step instructions:

<http://www.oxcryo.com/about/lmb-guide/>

SAFETY: gloves and goggles



What am I doing wrong?



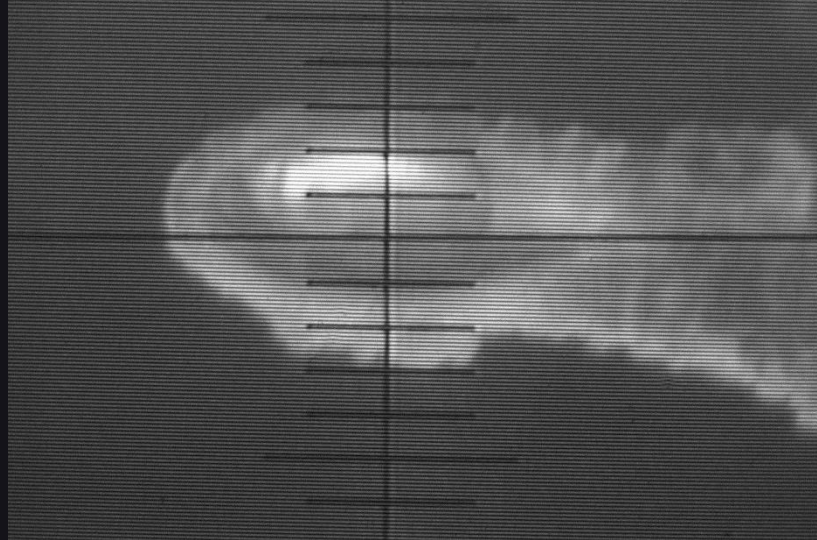

Absolutely NO ice of ANY sort.

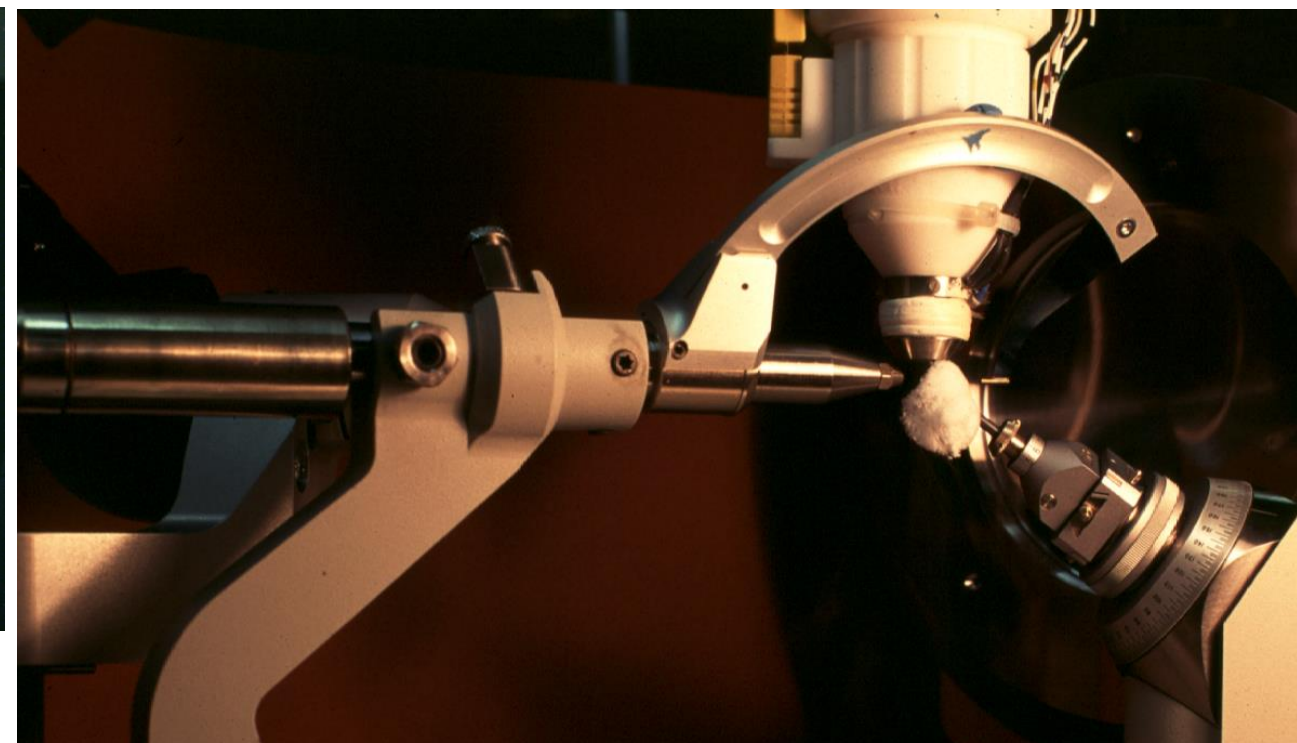
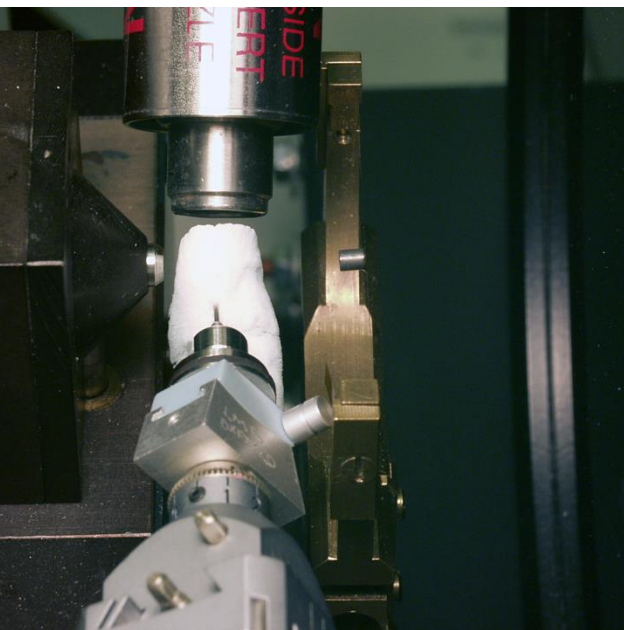

CRYSTAL SOAKS:

- Use same cooling protocol
[soak time, solution concentrations]
BEST to use same human being too!
- MIR/substrate- put it in the cryo-buffer too:
N.B.competitive inhibition with cryo-agent.
- Non-isomorphism: MR to native first

[Crick and Magdoff 1956]

Bound cryoprotectant agent.

Beware competitive inhibition with wanted substrate.
Put substrate in cryo-buffer.

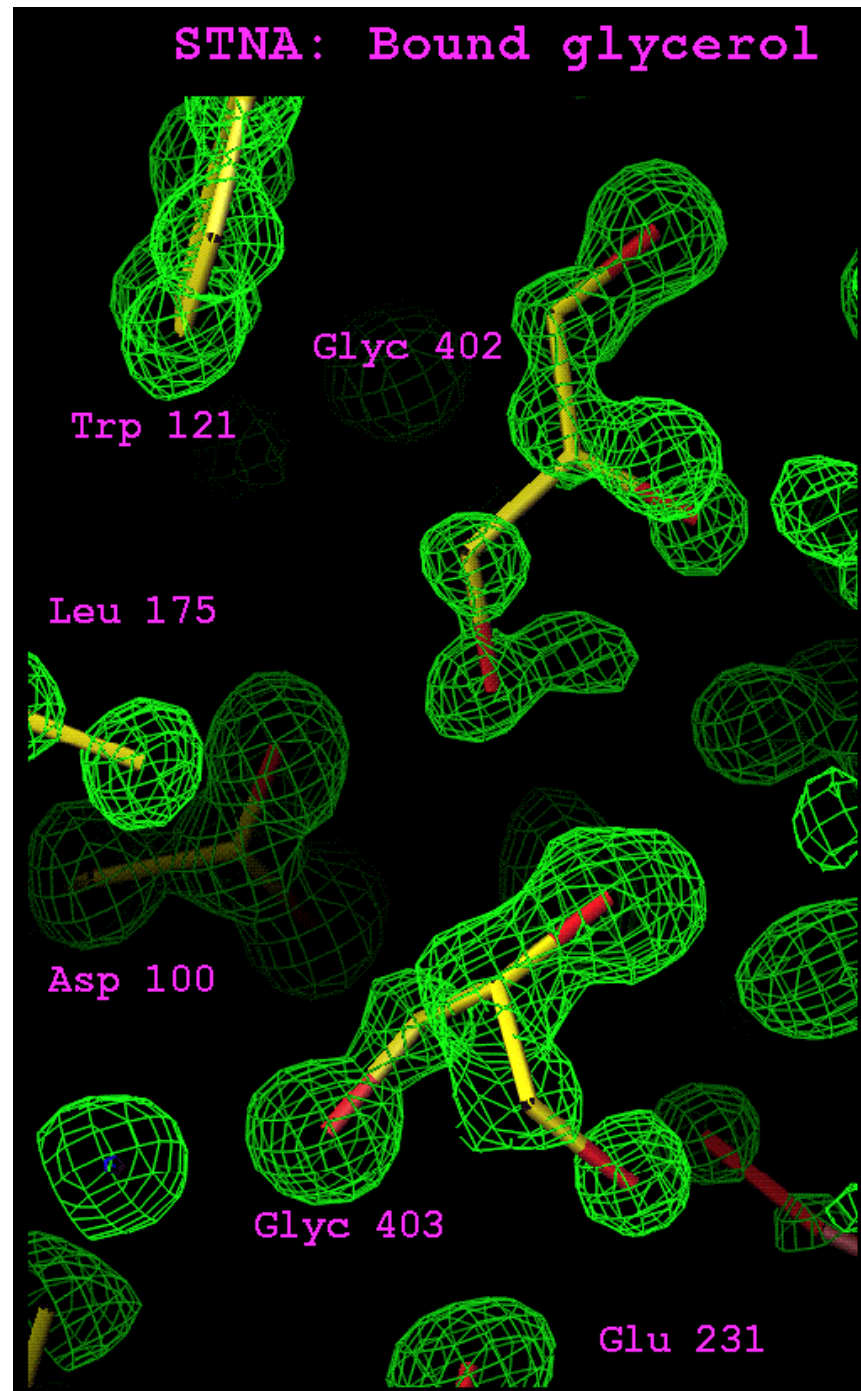

The Plan:

- Cryo techniques
 - Why cool? Radiation damage.
 - Optimising cryoprotection.
 - Testing at room temperature.
 - Storage and retrieval.
 - **If nothing seems to work....**

If nothing seems to work:

- **Diffraction at room temperature?**
- **Cryo-solutions**
- **Transfer/handling/soaking – vary time and temperature [e.g. try 4° overnight]**
- **Cryogen choice: nitrogen gas/liquid**
- Osmolarity matching
- Crystal annealing
- Swap buffer
- Try more than once.

Theoretical study: starts to rationalise experimental practice.

Heat transfer study by a proper mechanical engineer!

Most to least important factors:

- 1) Crystal solvent content and solvent composition.
- 2) Crystal size and shape.
- 3) Amount of residual liquid around the crystal
- 4) Cooling method (liquid plunge *versus* gas stream).
- 5) Choice of gas/liquid.
- 6) Relative speed between cooling fluid and crystal.

[S. Kriminski, M. Kazmierczak and R.E. Thorne

`Heat transfer from protein crystals: implications for flash-cooling and X-ray beam heating. *Acta Cryst.* (2003) **D59**, 697-708.]

If nothing seems to work:

- Diffraction at room temperature?
- Cryo-solutions
- Transfer/handling/soaking – vary time and temperature [try 4° overnight]
- Cryogen choice
- **Osmolarity matching**
- **Crystal annealing**
- Swap buffer
- Try more than once.

Copyrighted Farside cartoon
of slug vacation disasters (Salt Lake...)

Osmolarity matching:

- 1) Look up osmotic pressure of mother liquor in CRC Handbook of Physics and Chemistry, Section D-232. 11th column is O: Os/kg
- 2) Look up o.p. of cryoprotectant agent.
- 3) Modify conc. of mother liquor to minimise change in osmotic pressure.

Osmotic shock: compresses crystal \Rightarrow cracks
 \Rightarrow Mosaic spread increases \Rightarrow resolution lower.

'Quick dips' give greatest osmotic shock but minimise time for cryoprotectant attack.

23 GLYCEROL, CH₂OHCHOHCH₂OH

MOLECULAR WEIGHT = 92.09

RELATIVE SPECIFIC REFRACTIVITY = 1.109

0.00 % by wt. d:

For Values of 0

A % by wt.	ρ D ₄ ²⁰	D ₄ ²⁰	C, g/l	M g-mol/l	C _s g/l	(C _s - C ₀) g/l	(n - n ₀) × 10 ⁴	n	Δ °C	O Os/kg	S g-mol/l	η , η_s
0.50	0.9994	1.0011	5.0	0.054	994.4	3.9	6	1.3336	0.072	0.039	0.020	1.009
1.00	1.0005	1.0023	10.0	0.109	990.5	7.7	12	1.3342	0.180	0.097	0.051	1.020
2.00	1.0028	1.0046	20.1	0.218	982.7	15.5	23	1.3353	0.411	0.221	0.119	1.046
3.00	1.0051	1.0069	30.2	0.327	974.9	23.3	35	1.3365	0.627	0.337	0.182	1.072
4.00	1.0074	1.0092	40.3	0.438	967.1	31.2	46	1.3376	0.849	0.456	0.247	1.098
5.00	1.0097	1.0115	50.5	0.548	959.2	39.0	58	1.3388	1.078	0.580	0.315	1.125
6.00	1.0120	1.0138	60.7	0.659	951.3	46.9	70	1.3400	1.316	0.708	0.385	1.155
7.00	1.0144	1.0162	71.0	0.771	943.4	54.9	82	1.3412	1.561	0.839	0.457	1.186
8.00	1.0167	1.0185	81.3	0.883	935.4	62.9	94	1.3424	1.811	0.974	0.530	1.218
9.00	1.0191	1.0209	91.7	0.996	927.4	70.9	106	1.3436	2.064	1.110	0.603	1.253
10.00	1.0215	1.0233	102.1	1.109	919.3	78.9	118	1.3448	2.323	1.249	0.678	1.288
12.00	1.0262	1.0281	123.1	1.337	903.1	95.1	142	1.3472	2.880	1.548	0.837	1.362
14.00	1.0311	1.0329	144.4	1.568	886.7	111.5	167	1.3496	3.469	1.865	1.004	1.442
16.00	1.0360	1.0378	165.8	1.800	870.2	128.0	191	1.3521	4.094	2.201	1.177	1.530
18.00	1.0409	1.0428	187.4	2.035	853.6	144.7	217	1.3547	4.756	2.557	1.359	1.627
20.00	1.0459	1.0478	209.2	2.272	836.8	161.5	242	1.3572	5.46	2.93	1.546	1.734
24.00	1.0561	1.0580	253.5	2.752	802.6	195.6	294	1.3624	7.01	3.77	1.944	1.984
28.00	1.0664	1.0683	298.6	3.243	767.8	230.4	347	1.3676	8.77	4.71	2.370	2.274
32.00	1.0770	1.0789	344.6	3.742	732.3	265.9	400	1.3730	10.74	5.78	2.814	2.632
36.00	1.0876	1.0896	391.5	4.252	696.1	302.2	455	1.3785	12.96	6.97	3.276	3.082
40.00	1.0984	1.1003	439.4	4.771	659.0	339.2	511	1.3841	15.50	8.33	3.757	3.646
44.00	1.1092	1.1112	488.1	5.300	621.2	377.1	567	1.3897				4.434
48.00	1.1200	1.1220	537.6	5.838	582.4	415.8	624	1.3954				5.402
52.00	1.1308	1.1328	588.0	6.385	542.8	455.4	681	1.4011				6.653
56.00	1.1419	1.1439	639.4	6.944	502.4	495.8	739	1.4069				8.332
60.00	1.1530	1.1551	691.8	7.513	461.2	537.0	799	1.4129				10.66
64.00	1.1643	1.1663	745.1	8.091	419.1	579.1	859	1.4189				13.63
68.00	1.1755	1.1775	799.3	8.680	376.1	622.1	919	1.4249				18.42
72.00	1.1866	1.1887	854.3	9.277	332.2	666.0	980	1.4310				27.57
76.00	1.1976	1.1997	910.2	9.883	287.4	710.8	1040	1.4370				40.49
80.00	1.2085	1.2106	966.8	10.498	241.7	756.5	1101	1.4431				59.78
84.00	1.2192	1.2214	1024.2	11.121	195.1	803.2	1162	1.4492				84.17
88.00	1.2299	1.2320	1082.3	11.752	147.6	850.7	1223	1.4553				147.2
92.00	1.2404	1.2426	1141.1	12.392	99.2	899.0	1284	1.4613				383.7
96.00	1.2508	1.2530	1200.7	13.039	50.0	948.2	1344	1.4674				778.9
100.00	1.2611	1.2633	1261.1	13.694	0.0	998.2	1405	1.4735				1487.0

24 HYDROCHLORIC ACID, HCl

Osmotic Pressure Matching: Example

Osmality: Os/kg

- 2.0M NaCl
- 50mM pH 7.8 Tris HCl 3.95
- Need 20% glycerol 2.9
- 1.05

From Tables, 0.55M NaCl has o.p. 1.05 Os/kg

⇒ Try 0.55 M NaCl, 20% glycerol

50mM pH 7.8 Tris HCl

Crystal annealing: remove ice, reduce mosaicity and increase resolution

- Block stream temporarily (1-10 secs) OR
- Put crystal back in cryo-buffer solution.
- Then flash cool again.
- Worth a try (can repeat several times).
- Works sometimes.

[misnomer: slow heat and fast cool is really
'tempering']

Yeh and Hol (1998) *Acta Cryst.* D54, 479- 480.

Harp *et al.* (1998) *Acta Cryst* D54, 622-628, and (1999) D55, 1129-1134.

Hanson *et al.* (2003) *Meth Enzym* 368, 217

Understanding why annealing sometimes works.

Cryoprotectant agent concentration: match contraction of lattice to contraction of bulk solvent to avoid lattice distortion, higher mosaicity etc.

Not enough cryoprotectant

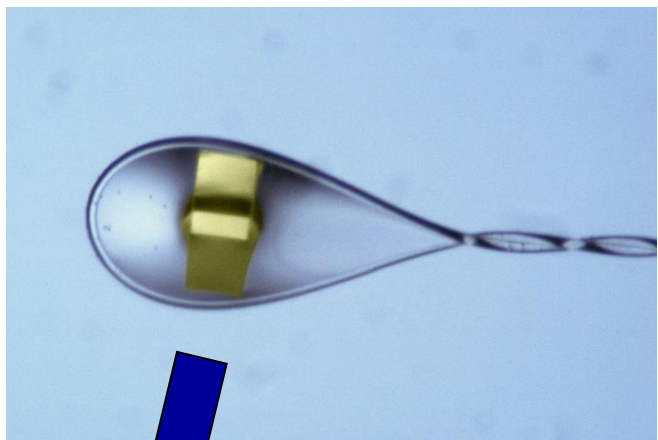

Water exported

Too much cryoprotectant

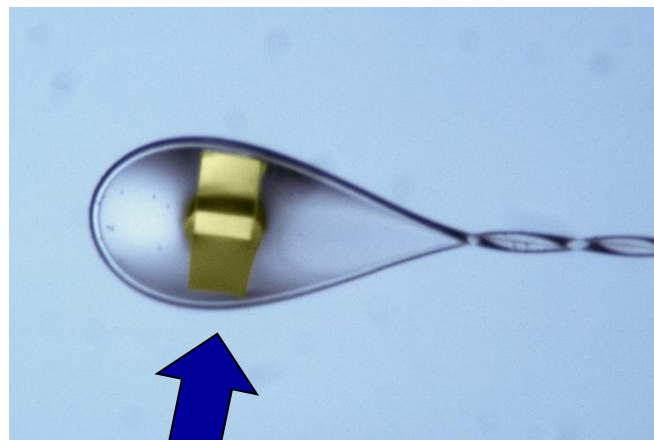

Water imported

If nothing seems to work:

- Diffraction at room temperature?
- Cryo-solutions
- Transfer/handling/soaking – vary time and temperature [4°]
- Cryogen choice
- Osmolarity matching
- Crystal annealing
- **Swap buffer**
- **Try more than once.**

Have at least 6 goes...

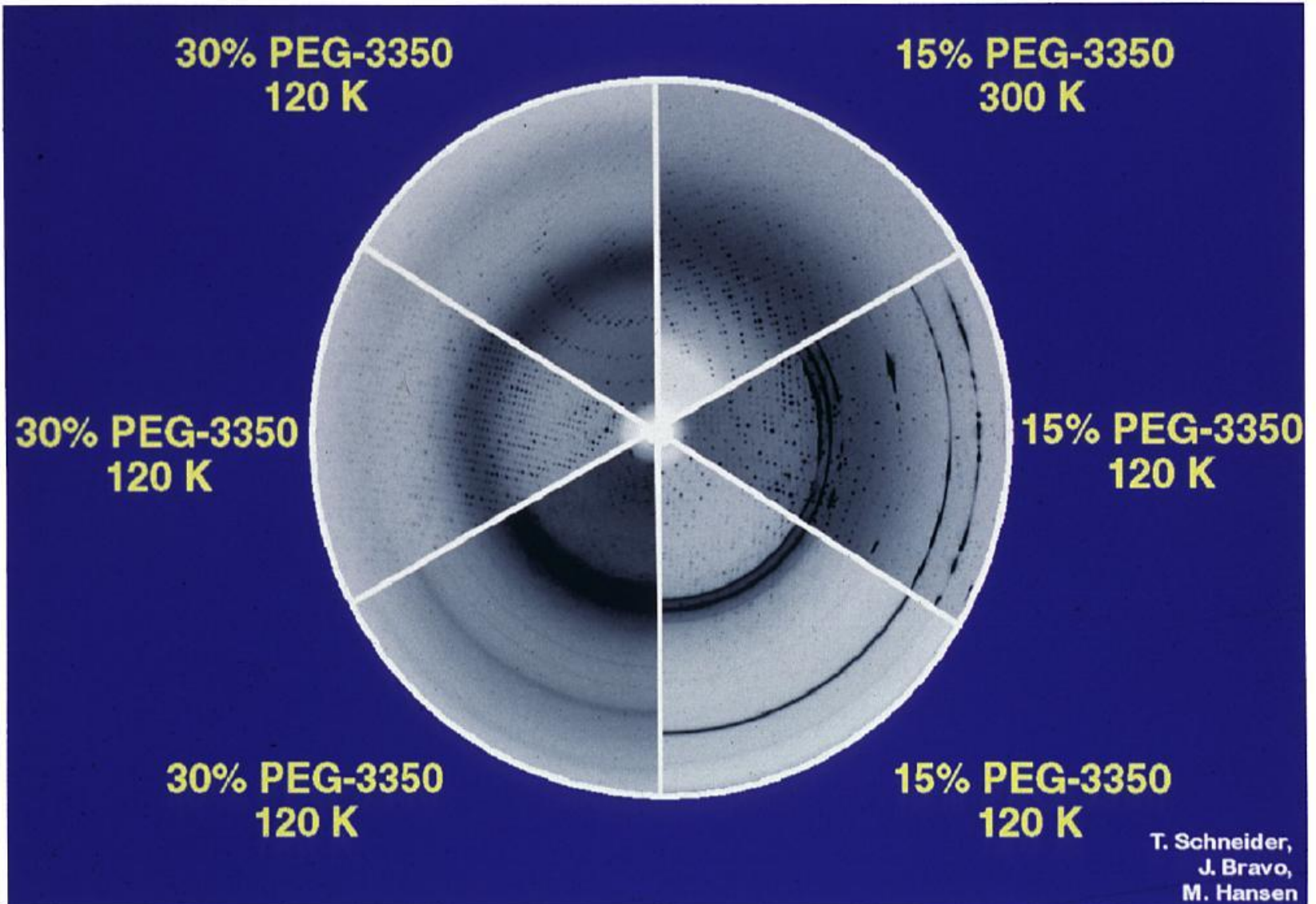

CRYO-COOLING:

Advantages

- Reduced radiation damage.
- Gentler mounting
- Lower background
- Higher resolution
- Fewer crystals
- Can ship crystals
- Use crystals when ready.

Disadvantages

- Expensive equipment
- Increase in mosaic spread.
- Need to invest time.

Cryocrystallography: for more gory details see:

- Rodgers, D (1997) *Methods in Enzymology* 276, 183-203 and in *International Tables of Crystallography Volume F* (2001) 202-208.
- Hope, H in *International Tables of Crystallography Volume F* (2001) 197-201.
- Garman and Schneider (1997) *J.Appl. Cryst.* 30, 211-237.
- Parkin and Hope (1998) *J.Appl. Cryst.* 31, 945-953.
- Garman (1999) *Acta D*55, 1641-1653.
- Garman and Doublie (2003) *Methods in Enzym.* 396, 188-216.
- Garman (2003) *Curr. Opin. Struct. Biol.* 13, 545-551.
- Garman and Owen, (2006) *Acta Cryst. D* 62, 32-47.
- Pflugrath (2015) *Acta Cryst F* 71, 622-642.

The Crystallographer's DILEMMA:

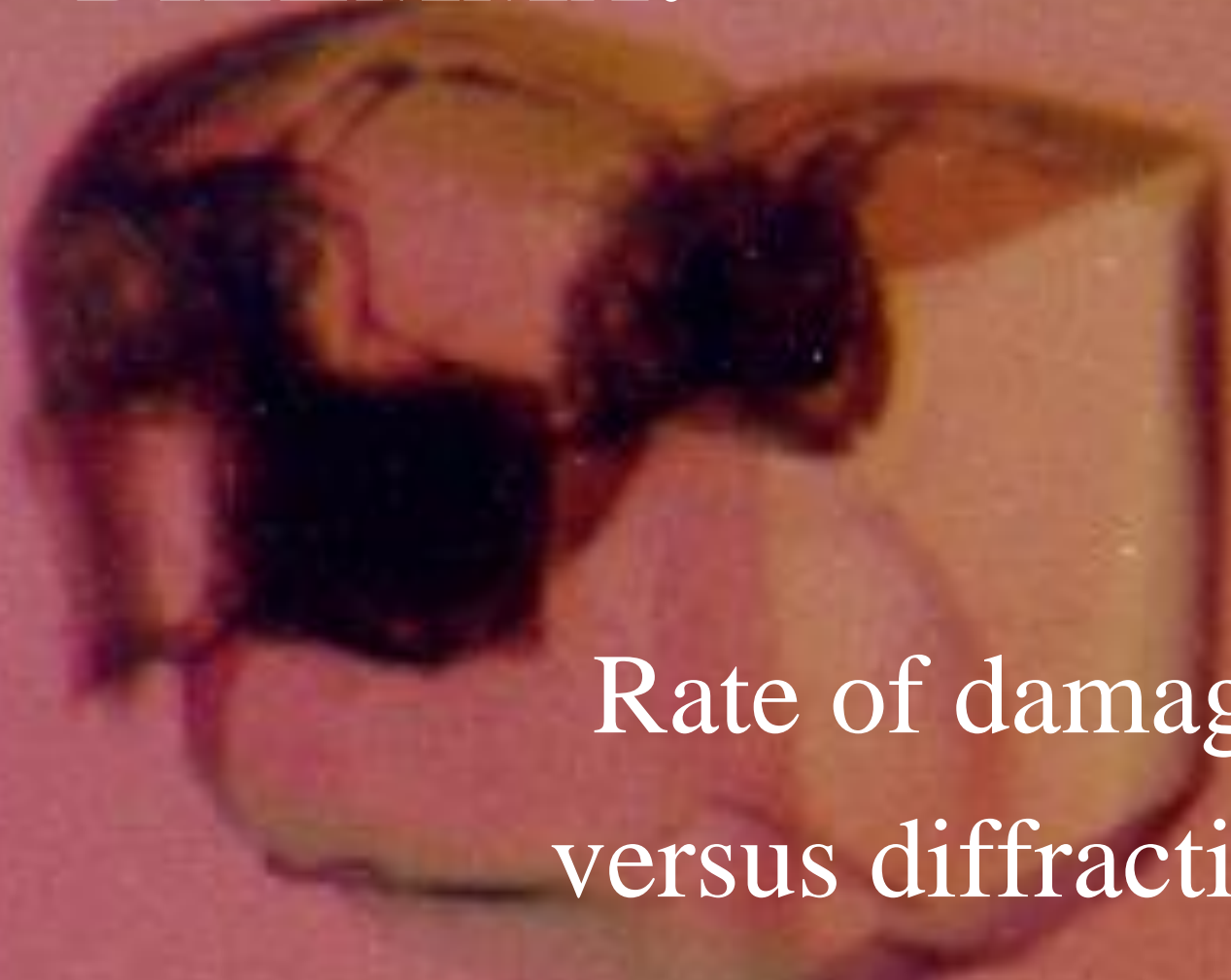

Rate of damage
versus diffraction
intensity

CCP4/DLS Workshop 2017.



Still the first day and my brain is already over full...