

Alternating distances of knots and links

Adam Lowrance - Vassar College

November 8, 2014

Alternating distance

An integer valued knot invariant $d(K)$ is an *alternating distance* if

- $d(K) \geq 0$ for every knot K ,
- $d(K) = 0$ if and only if K is alternating, and
- $d(K_1 \# K_2) \leq d(K_1) + d(K_2)$ for all knots K_1 and K_2 .

Comparing alternating distances

Let d_1 and d_2 be alternating distances, and let \mathcal{F} be some family of knots. We say d_1 dominates d_2 on \mathcal{F} if for each positive integer n , there exists a knot $K_n \in \mathcal{F}$ such that

$$d_1(K_n) - d_2(K_n) \geq n.$$

The Turaev surface

- Knot diagram $D \rightsquigarrow$ Turaev surface $F(D)$.
- Turaev (1987) used $F(D)$ to give simplified proofs of some Tait conjectures.
- DFKLS (2006) - Connections with the Jones polynomial.
- Champanerkar, Kofman, and Stoltzfus (2007) - Connections with Khovanov homology.
- L. (2007) - Connections with knot Floer homology.
- Dasbach, L. (2009) - Connections with signature, and the s and τ invariants.

Construction of the Turaev surface $F(D)$

1. Replace crossings of D with disks.
2. Replace strands of D between crossings with (sometimes twisted) bands.
3. Cap off the boundary components with disks to obtain $F(D)$.

The Turaev surface - in pictures

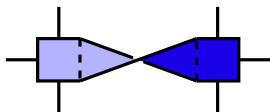
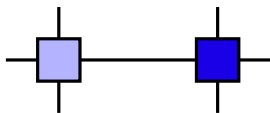
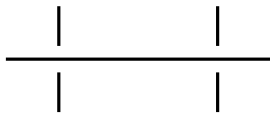
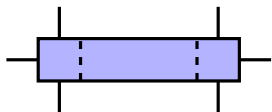
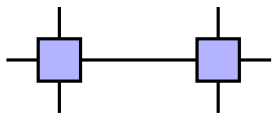
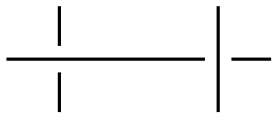

An alternating example

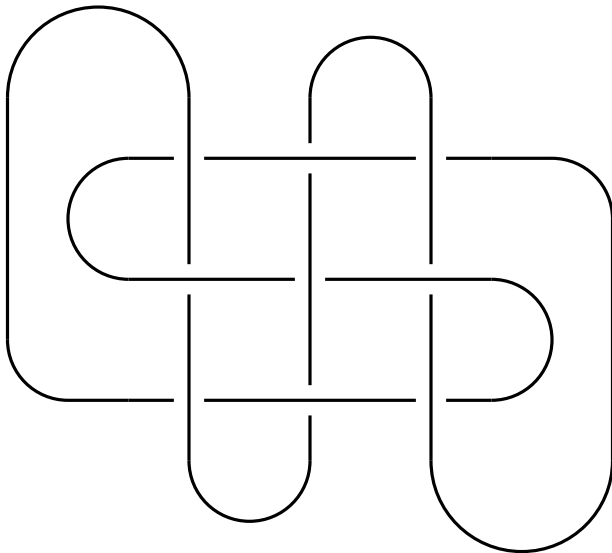

An alternating example

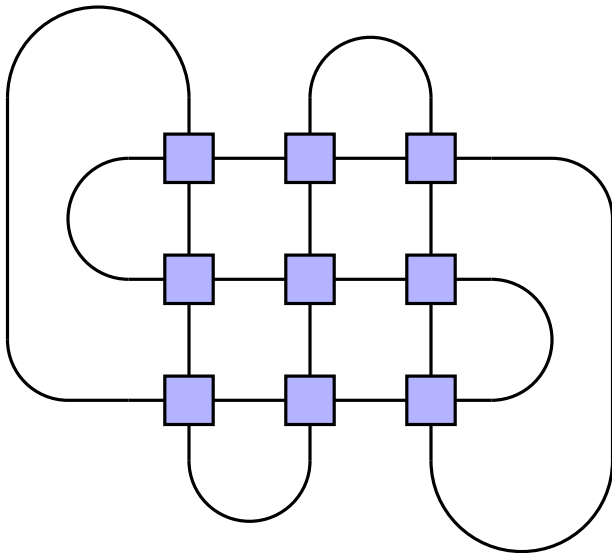

An alternating example

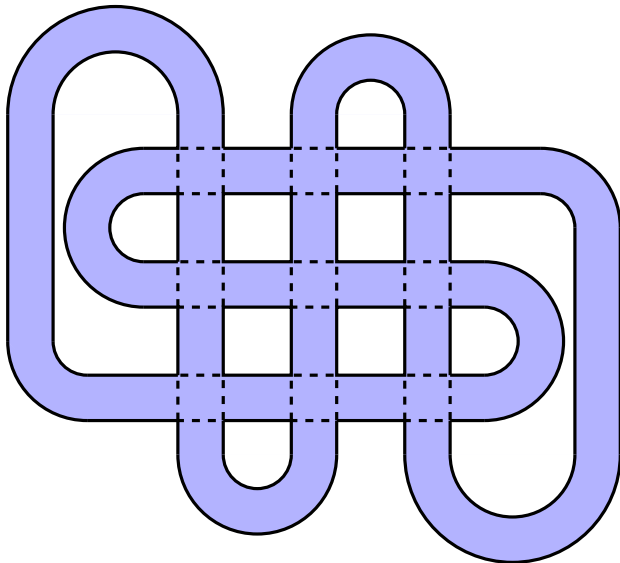

An alternating example

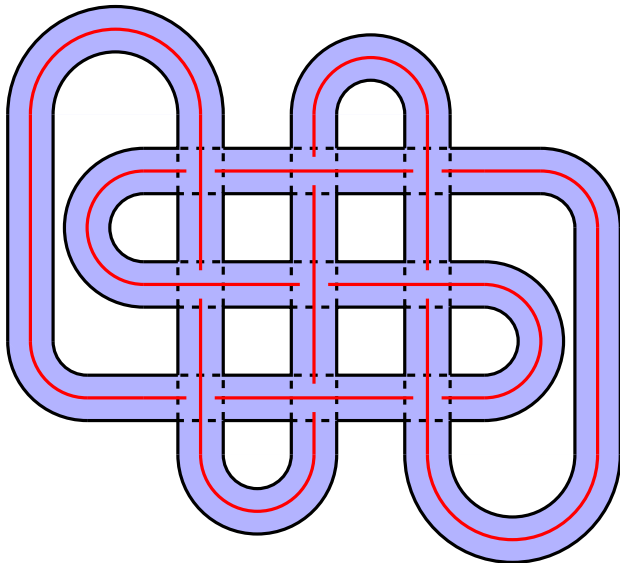

A non-alternating example

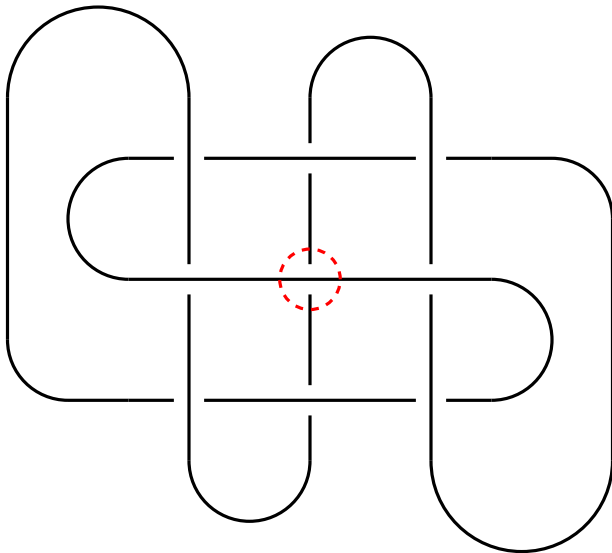

A non-alternating example

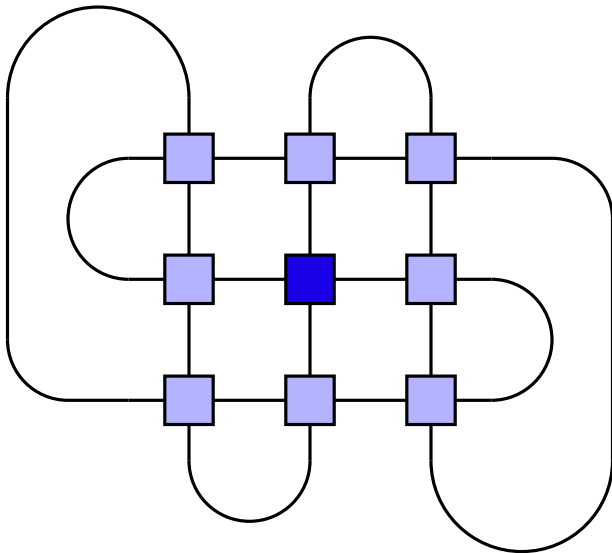

A non-alternating example

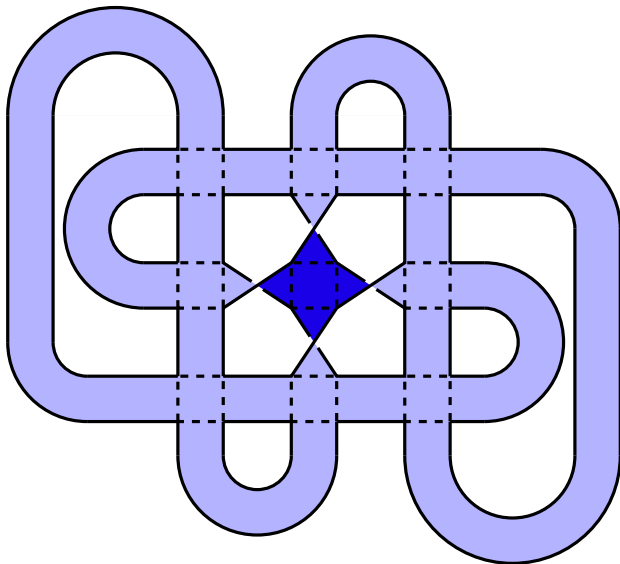

A non-alternating example

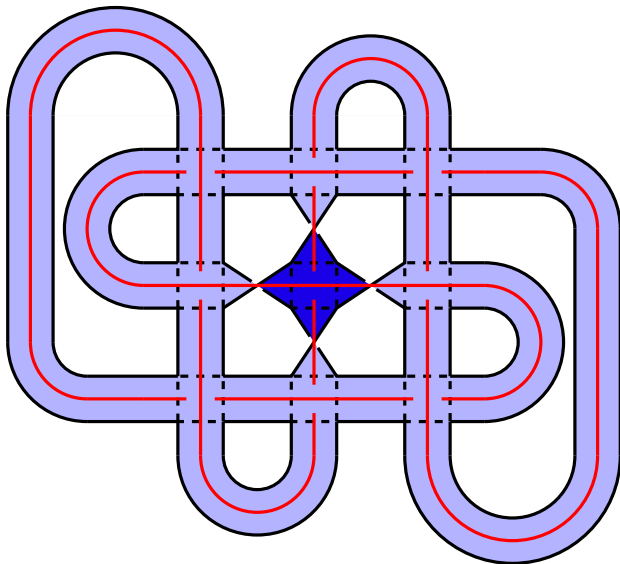

Turaev genus

The Turaev genus $g_T(K)$ of the knot K is

$$g_T(K) = \min\{g(F(D)) \mid D \text{ is a diagram of } K\}.$$

Theorem (DFKLS)

*The Turaev genus of K is zero if and only if K is alternating.
Moreover, the Turaev genus of a knot is an alternating distance.*

More facts about the Turaev surface

1. $F(D)$ is a Heegaard surface in S^3 .
2. D is alternating on $F(D)$.
3. The complement of D in $F(D)$ is a collection of disks that can be two-colored in a checkerboard fashion.

Question. If a surface satisfies (1) - (3) above, is it the Turaev surface of some knot?

Answer. No.

Alternating genus of a knot

- Let $g_{\text{alt}}(K)$ denote the minimum genus surface satisfying (1)-(3) from the previous slide.
- Knots K with $g_{\text{alt}}(K) = 1$ were studied by Adams (1994).
- The alternating genus of a knot is an alternating distance.
- $g_{\text{alt}}(K) \leq g_{\mathcal{T}}(K)$ for any knot, but there exists knots where $g_{\mathcal{T}}(K)$ is much larger than $g_{\text{alt}}(K)$.

A modified torus knot $\tilde{T}_{4,4k+3}$

Let B_4 be the braid group on 4-strands, and let $\Delta \in B_4$ denote the braid

$$\Delta = \sigma_1 \sigma_2 \sigma_3.$$

Let $\tilde{\Delta}$ denote the braid

$$\tilde{\Delta} = \sigma_1 \sigma_2^{-1} \sigma_3.$$

For each non-negative integer k , define $\tilde{T}_{4,4k+3}$ to be the closure of the braid

$$\Delta^{4k+2} \tilde{\Delta}.$$

Let $\mathcal{F}(\tilde{T}_{4,4k+3})$ be the set of such modified torus knots.

Example: $\tilde{T}_{4,3}$

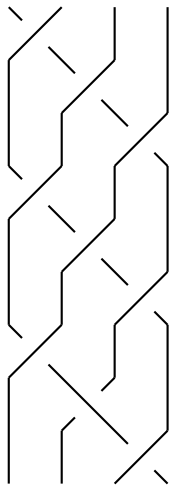

Example: $\tilde{T}_{4,3}$

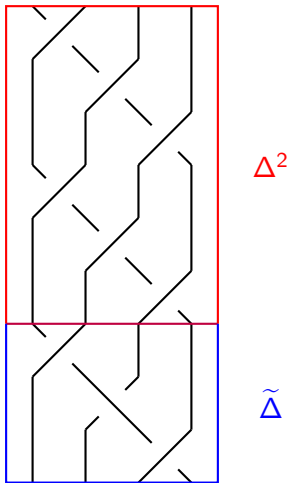

Turaev genus dominates alternating genus

Theorem

Turaev genus dominates alternating genus on $\mathcal{F}(\tilde{T}_{4,4k+3})$.

Overview of proof.

- $g_{\text{alt}}(\tilde{T}_{4,4k+3}) = 1$ for any non-negative integer k .
- $g_T(\tilde{T}_{4,4k+3}) \rightarrow \infty$ as $k \rightarrow \infty$.

The alternating genus of $\tilde{T}_{4,4k+3}$

$\tilde{T}_{4,3}$

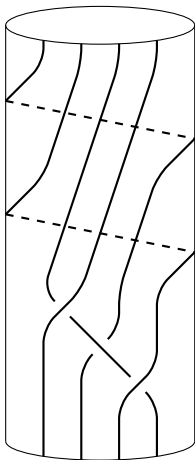

$\tilde{T}_{4,4k+3}$

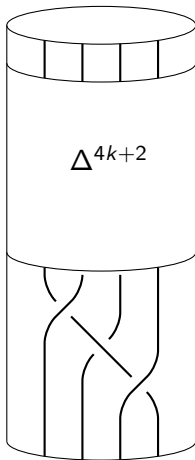

The alternating genus of $\tilde{T}_{4,4k+3}$

$\tilde{T}_{4,3}$

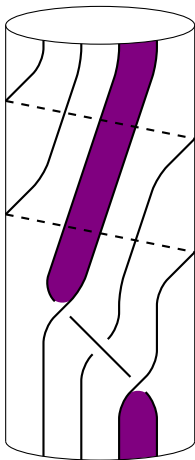

$\tilde{T}_{4,4k+3}$

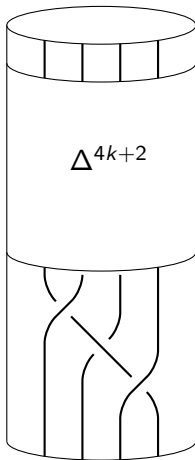

The alternating genus of $\tilde{T}_{4,4k+3}$

$\tilde{T}_{4,3}$

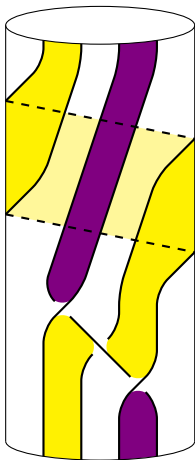

$\tilde{T}_{4,4k+3}$

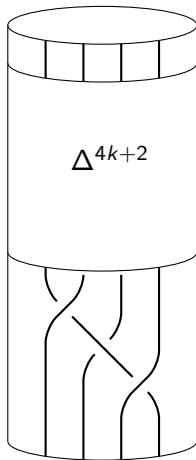

The alternating genus of $\tilde{T}_{4,4k+3}$

$\tilde{T}_{4,3}$

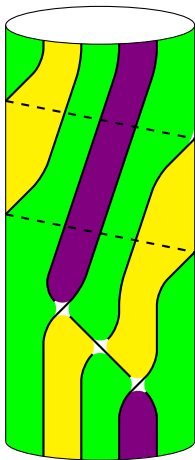

$\tilde{T}_{4,4k+3}$

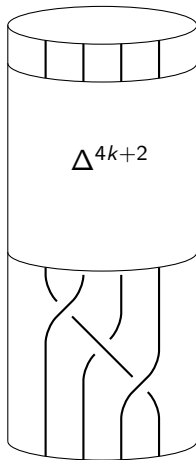

The Turaev genus of $\tilde{T}_{4,4k+3}$

1. Dasbach, L. (2009) For any knot K ,

$$|s(K) + \sigma(K)| \leq 2g_T(K).$$

2. Use Gordon, Litherland, and Murasugi (1981) to compute $\sigma(T_{4,4k+3})$.
3. The Rasmussen s invariant and the signature of a knot can change by at most two for each crossing change.
4. Use (2) and (3) to show that $|s(\tilde{T}_{4,4k+3}) + \sigma(\tilde{T}_{4,4k+3})| \rightarrow \infty$ as $k \rightarrow \infty$.
5. Thus (1) implies $g_T(\tilde{T}_{4,4k+3}) \rightarrow \infty$ as $k \rightarrow \infty$.

Sufficient conditions for being a Turaev surface

Recall that the Turaev surface $F(D)$ satisfies the following.

1. $F(D)$ is a Heegaard surface in S^3 .
2. D is alternating on $F(D)$.
3. The complement of D in $F(D)$ is a collection of disks that can be two-colored in a checkerboard fashion.

Sufficient conditions for being a Turaev surface.

- Champanerkar, Kofman (2014) - Conditions (1)-(3) plus a Morse theoretic condition.
- Armond, Druivenga, Kindred (in progress) - Conditions (1)-(3) plus a Heegaard diagram condition.

The dealternating number

Let D be a diagram of K . The dealternating number of D , denoted $\text{dalt}(D)$, is the minimum number of crossing changes required to transform D into an alternating diagram.

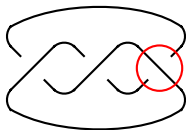

$$\text{dalt}(D) = 1$$

Adams (1992) defines the dealternating number of K as

$$\text{dalt}(K) = \min\{\text{dalt}(D) \mid D \text{ is a diagram of } K\}.$$

The alternation number

Let D be a diagram of K . The alternation number of D , denoted $\text{alt}(D)$, is the minimum number of crossing changes required to transform D into a (possibly non-alternating) diagram of an alternating knot.

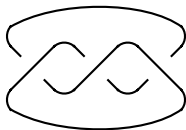

$$\text{alt}(D) = 0$$

Kawauchi (2010) defines the alternation number of K as

$$\text{alt}(K) = \min\{\text{alt}(D) \mid D \text{ is a diagram of } K\}.$$

More alternating distances

- The dealternating number of a knot is an alternating distance.
- The alternation number of a knot is an alternating distance.
- Let $c(K)$ denote the crossing number of K , and let $V_K(t)$ denote the Jones polynomial of K . Then

$$c(K) - \text{span } V_K(t)$$

is an alternating distance (Kauffman - 1987, Murasugi - 1987).

Inequalities

The following inequalities hold for every knot K :

1. $g_{\text{alt}}(K) \leq g_{\mathcal{T}}(K)$.
2. $\text{alt}(K) \leq \text{dalt}(K)$.
3. $g_{\mathcal{T}}(K) \leq \text{dalt}(K)$ (Abe - 2008).
4. $g_{\mathcal{T}}(K) \leq c(K) - \text{span } V_K(t)$ (Turaev - 1987).

Our inequalities

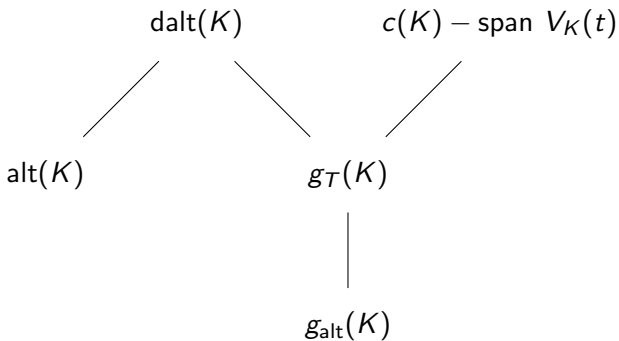

Whitehead doubles

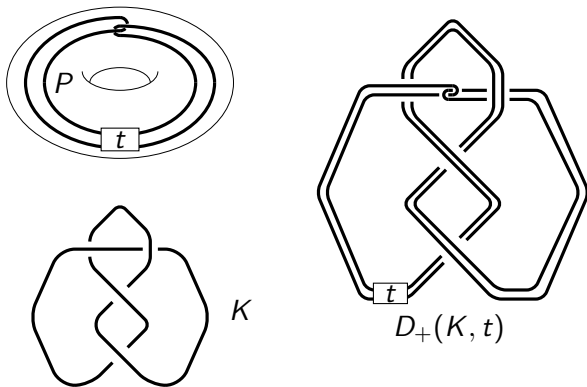

The t -twisted positive Whitehead double of K

Turaev genus dominates alternation number

Let W_n be the n -th iterated, positive, untwisted Whitehead double of the figure-eight knot. Let $\mathcal{F}(W_n)$ be the set of all W_n .

Theorem

Turaev genus dominates alternation number on $\mathcal{F}(W_n)$.

Proof sketch.

- $\text{alt}(W_n) = 1$ for each $n > 0$.
- Knot Floer homology tells us $g_T(W_n) \rightarrow \infty$ as $n \rightarrow \infty$.

Alternation number and alternating genus

Theorem

The alternation number and alternating genus of a knot are not comparable.

Proof sketch.

- Using a similar argument from before, we have

$$g_{\text{alt}}(\tilde{T}_{4,4k+3}) < \text{alt}(\tilde{T}_{4,4k+3}).$$

- Adams (1994) proves that $g_{\text{alt}}(W_n) > 1$ and so

$$\text{alt}(W_n) < g_{\text{alt}}(W_n).$$

$c(K) - \text{span } V_K(t)$ dominates dealternating number

Theorem

The difference $c(K) - \text{span } V_K(t)$ dominates the dealternating number on the set of $(3, q)$ -torus knots.

The proof pieces together prior results of Jones (1987), Murasugi (1991) and Abe (2008).

Open Questions

1. Are the Turaev genus and the dealternating number the same invariant, i.e. does $g_T(K) = \text{dalt}(K)$ for every knot K ?
2. Is $\text{dalt}(K) \leq c(K) - \text{span } V_K(t)$ for every knot K ?
3. Is $\text{alt}(K) \leq c(K) - \text{span } V_K(t)$ for every knot K ?
4. Is $\text{alt}(K) \leq g_T(K)$ for every knot K ?